

Part No. 060510-10, Rev. L
October 2022

OmniSwitch 6465 Hardware Users Guide

Alcatel·Lucent 
Enterprise

www.al-enterprise.com

This user guide documents OmniSwitch 6465 hardware, including chassis and associated components. The specifications described in this guide are subject to change without notice.

The Alcatel-Lucent name and logo are trademarks of Nokia used under license by ALE. To view other trademarks used by affiliated companies of ALE Holding, visit: www.al-enterprise.com/en/legal/trademarks-copyright. All other trademarks are the property of their respective owners. The information presented is subject to change without notice. Neither ALE Holding nor any of its affiliates assumes any responsibility for inaccuracies contained herein. © Copyright 2022 ALE International, ALE USA Inc. All rights reserved in all countries.



26801 West Agoura Road
Calabasas, CA 91301
(818) 880-3500 FAX (818) 880-3505

Service & Support Contact Information

North America: 800-995-2696
Latin America: 877-919-9526
EMEA: +800 00200100 (Toll Free) or +1(650)385-2193
Asia Pacific: +65 6240 8484
Web: myportal.al-enterprise.com
Email: ebg_global_supportcenter@al-enterprise.com

Contents

	About This Guide	ix
	Supported Platforms	ix
	Who Should Read this Manual?	ix
	When Should I Read this Manual?	ix
	What is in this Manual?	x
	What is Not in this Manual?	x
	How is the Information Organized?	x
	Documentation Roadmap	xi
	Related Documentation	xiii
	Technical Support	xiv
Chapter 1	OmniSwitch 6465	1-1
	OmniSwitch 6465 Availability Features	1-2
	Power Supply Redundancy	1-2
	Hot-Swapping	1-2
	Hardware Monitoring	1-2
Chapter 2	Getting Started	2-1
	Installing the Hardware	2-1
	Items Required	2-1
	Site Preparation	2-1
	Environmental Requirements	2-1
	Electrical Requirements	2-1
	Electrical Surge Warning	2-2
	Unpacking and Installing the Switch	2-2
	Items Included	2-3
	Weight Considerations	2-3
	Connections and Cabling	2-4
	Network Cable Installation Warning	2-4
	Serial Connection to the Console Port	2-4
	Serial Connection Default Settings	2-4
	Booting the Switch	2-5
	Component LEDs	2-5
	Your First Login Session	2-6
	Logging In to the Switch	2-6
	Unlocking Session Types	2-7
	Changing the Login Password	2-7
	Setting the System Time Zone	2-8

Setting the Date and Time	2-8
Setting Optional Parameters	2-8
Specifying an Administrative Contact	2-8
Specifying a System Name	2-8
Specifying the Switch's Location	2-8
Viewing Your Changes	2-9
Saving Your Changes	2-9
Chapter 3	
Chassis and Power Supplies	3-1
OmniSwitch 6465 Chassis Details	3-2
OS6465-P6	3-2
OS6465-P6 Front Panel	3-2
OS6465-P6 Rear Panel	3-3
OS6465-P6 Chassis Specifications	3-4
OS6465-P12	3-5
OS6465-P12 Front Panel	3-5
OS6465-P12 Rear Panel	3-6
OS6465-P12 Chassis Specifications	3-7
OS6465-P12 (ENH-240)	3-8
OS6465-P12 (ENH-240) Front Panel	3-8
OS6465-P12 (ENH-240) Rear Panel	3-9
OS6465-P12 (ENH-240) Chassis Specifications	3-10
OS6465-P28	3-11
OS6465-P28 Front Panel	3-11
OS6465-P28 Rear Panel	3-11
OS6465-P28 Chassis Specifications	3-12
OS6465T-12	3-13
OS6465T-12 Front Panel	3-13
OS6465T-12 Rear Panel	3-14
OS6465T-12 Chassis Specifications	3-14
OS6465T-P12	3-15
OS6465T-P12 Front Panel	3-15
OS6465T-P12 Rear Panel	3-16
OS6465T-P12 Chassis Specifications	3-16
Chassis Status LEDs	3-17
Mounting the Switch	3-18
General Mounting Recommendations	3-18
Airflow / Clearance Recommendations	3-18
DIN Rail Mounting	3-18
DIN Rail Unmounting	3-19
Rack Mounting Steps (Full-width Chassis)	3-20
Rack Mounting Steps (One Half-width Chassis - OS6465T-RM-19-L Kit)	3-21
Rack Mounting Steps (Two Half-width Chassis - OS6465T-DUO-MNT Kit)	3-23
Side Mounting Steps	3-26
DNV Mounting Steps	3-27
Power Supplies	3-30
OS6465-BPN-X AC Power Supply	3-31
LED States	3-31
OS6465-BPN-H AC Power Supply	3-32
LED States	3-32

OS6465-BPN AC Power Supply	3-33
LED States	3-33
OS6465-BPR Power Supply	3-34
OS6465-BPRD 180W DC Power Supply	3-35
Internal Power Supplies	3-36
Connecting the AC Power Supplies	3-38
Connecting the Removed Outer Jacket (ROJ) Power Cords	3-38
Final Power Cord Connections	3-40
Configuring a Power Supply	3-40
Hot-Swapping / Removing a Power Supply	3-41
Grounding the Chassis	3-41
Alarm Relay	3-42
Alarm Relay Configuration Examples	3-43
Monitoring Chassis Components	3-44
Viewing Chassis Slot Information	3-44
Monitoring Chassis Temperature	3-44
Temperature Errors	3-45
Dying Gasp	3-45
Scenarios	3-45
SNMP Trap	3-46
Syslog Message	3-46
Link OAM PDU	3-46
Link OAM PDU Priority	3-46
Chapter 4 Managing Power over Ethernet (PoE)	4-1
In This Chapter	4-2
Power over Ethernet Specifications	4-3
Power over Ethernet Defaults	4-3
Power over Ethernet Budget	4-4
Viewing Power Supply Status	4-4
Viewing PoE Status	4-6
Understanding and Modifying the Default Settings	4-6
PoE Class Detection	4-6
PoE Operational Status	4-7
Configuring the Total Power Available to a Port	4-7
Configuring the Total Power Available to a slot	4-8
Setting Port Priority Levels	4-8
Setting the Capacitor Detection Method	4-9
Understanding Guard Band	4-9
Understanding Priority Disconnect	4-11
Setting Priority Disconnect Status	4-11
Disabling Priority Disconnect	4-11
Enabling Priority Disconnect	4-11
Priority Disconnect is Enabled; Same Priority Level on All PD	4-12
Priority Disconnect is Enabled; Incoming PD Port has Highest Priority Level	4-12

Priority Disconnect is Enabled; Incoming PD Port has Lowest Priority Level	4-12
Priority Disconnect is Disabled	4-13
Monitoring Power over Ethernet via CLI	4-14
Appendix A Regulatory Compliance and Safety Information	A-1
Declaration of Conformity: CE Mark	A-1
Waste Electrical and Electronic Equipment (WEEE) Statement	A-1
China RoHS: Hazardous Substance Table	A-2
Taiwan RoHS: Hazardous Substance Table	A-3
California Proposition 65 Warning	A-3
Standards Compliance	A-4
FCC Class A, Part 15	A-7
Canada Class A Statement	A-7
JATE	A-7
CISPR22 Class A warning	A-7
Korea Emissions Statement	A-8
VCCI	A-8
Class A Warning for Taiwan and Other Chinese Markets	A-8
Class 1M Laser Warning	A-8
Network Cable Installation Warning	A-8
Translated Safety Warnings	A-9
Blank Panels Warning	A-9
Electrical Storm Warning	A-9
Installation Warning	A-9
Invisible Laser Radiation Warning	A-10
Operating Voltage Warning	A-10
Power Disconnection Warning	A-10
Proper Earthing Requirement Warning	A-11
DC Power Supply Connection Warning	A-11
Read Important Safety Information Warning	A-12
Restricted Access Location Warning	A-12
Wrist Strap Warning	A-12
Instrucciones de seguridad en español	A-13
Advertencia sobre el levantamiento del chasis	A-13
Advertencia de las tapaderas en blanco	A-13
Advertencia en caso de tormenta eléctrica	A-13
Advertencia de instalación	A-13
Advertencia de radiación láser invisible	A-13
Advertencia de la batería de litio	A-13
Advertencia sobre la tensión de operación	A-13
Advertencia sobre la desconexión de la fuente	A-13
Advertencia sobre una apropiada conexión a tierra	A-14
Leer “información importante de seguridad”	A-14
Advertencia de acceso restringido	A-14
Advertencia de pulsera antiestática	A-14
Clase de seguridad	A-14

Advertencia de fuentes de poder A-14

About This Guide

This *OmniSwitch 6465 Hardware Users Guide* describes OmniSwitch 6465 switch components and basic switch hardware procedures.

Supported Platforms

The information in this guide applies only to OmniSwitch 6465 switches.

Who Should Read this Manual?

The audience for this users guide is network administrators and IT support personnel who need to configure, maintain, and monitor switches and routers in a live network. However, anyone wishing to gain knowledge of the hardware will benefit from the material in this guide.

When Should I Read this Manual?

Read this guide as soon as you are ready to familiarize yourself with your switch hardware components.

You should already be familiar with the very basics of the switch hardware, such as module LEDs and component installation procedures. This manual will help you understand your switch hardware in greater depth.

What is in this Manual?

This users guide includes the following hardware-related information:

- Descriptions of “Availability” features.
- Technical specifications for the chassis, power supplies and modules.
- Power supply requirements.
- The dynamics of chassis airflow, including detailed illustrations of proper and improper airflow configurations.
- Hot-swapping power supplies.
- Installation and removal procedures for power supplies and modules.
- Detailed illustrations and LED descriptions for chassis, network and power supply operability.
- Hardware-related Command Line Interface (CLI) commands.

What is Not in this Manual?

The descriptive and procedural information in this manual focuses on switch hardware. It includes information on some CLI commands that pertain directly to hardware configuration, but it is not intended as a software users guide. There are several OmniSwitch users guides that focus on switch software configuration. Consult those guides for detailed information and examples for configuring your switch software to operate in a live network environment. See [“Documentation Roadmap” on page -xi](#) and [“Related Documentation” on page -xiii](#) for further information on software configuration guides available for your switch.

How is the Information Organized?

Each chapter in this guide focuses on a specific hardware component or a set of hardware components. All descriptive, technical specification, and procedural information for a hardware component can be found in the chapter dedicated to that component.

Documentation Roadmap

The OmniSwitch user documentation suite was designed to supply you with information at several critical junctures of the configuration process. The following section outlines a roadmap of the manuals that will help you at each stage of the configuration process. Under each stage, we point you to the manual or manuals that will be most helpful to you.

Stage 1: Using the Switch for the First Time

Pertinent Documentation: *Getting Started Information*
Release Notes

A “Getting Started” chapter is included in the *OmniSwitch 6465 Hardware Users Guide*. This chapter provides all the information you need to get your switch up and running the first time. It also includes succinct overview information on fundamental aspects of the switch.

At this time you should also familiarize yourself with the Release Notes that accompanied your switch. This document includes important information on feature limitations that are not included in other user guides.

Stage 2: Gaining Familiarity with Basic Switch Functions

Pertinent Documentation: *Hardware Users Guide*
OmniSwitch AOS Release 8 Switch Management Guide

Once you have your switch up and running, you will want to begin investigating basic aspects of its hardware and software. Information about switch hardware is provided in the *OmniSwitch 6465 Hardware Guide*. This guide provides specifications, illustrations, and descriptions of all hardware components. It also includes steps for common procedures, such as removing and installing switch components.

This guide is the primary users guide for the basic software features on a single switch. This guide contains information on the switch directory structure, basic file and directory utilities, switch access security, SNMP, and web-based management. It is recommended that you read this guide before connecting your switch to the network.

Stage 3: Integrating the Switch Into a Network

Pertinent Documentation: *OmniSwitch AOS Release 8 Network Configuration Guide*

When you are ready to connect your switch to the network, you will need to learn how the OmniSwitch implements fundamental software features, such as 802.1Q, VLANs, Spanning Tree, and network routing protocols. The *Network Configuration Guide* guide contains overview information, procedures, and examples on how standard networking technologies are configured on the OmniSwitch.

Anytime

The *OmniSwitch AOS Release 8 CLI Reference Guide* contains comprehensive information on all CLI commands supported by the switch. This guide includes syntax, default, usage, example, related CLI command, and CLI-to-MIB variable mapping information for all CLI commands supported by the switch. This guide can be consulted anytime during the configuration process to find detailed and specific information on each CLI command.

Related Documentation

The following are the titles and descriptions of all the OmniSwitch 6465 user manuals:

- *OmniSwitch 6465 Hardware Users Guide*

Complete technical specifications and procedures for all OmniSwitch 6465 chassis, power supplies, and Network Interface (NI) modules.

- *OmniSwitch AOS Release 8 CLI Reference Guide*

Complete reference to all CLI commands supported on the OmniSwitch. Includes syntax definitions, default values, examples, usage guidelines and CLI-to-MIB variable mappings.

- *OmniSwitch AOS Release 8 Switch Management Guide*

Includes procedures for readying an individual switch for integration into a network. Topics include the software directory architecture, image rollback protections, authenticated switch access, managing switch files, system configuration, using SNMP, and using web management software (WebView).

- *OmniSwitch AOS Release 8 Network Configuration Guide*

Includes network configuration procedures and descriptive information on all the major software features and protocols included in the base software package. Chapters cover Layer 2 information (Ethernet and VLAN configuration), Layer 3 information (routing protocols, such as RIP and IPX), security options (authenticated VLANs), Quality of Service (QoS), link aggregation, and server load balancing.

- Technical Tips, Field Notices

Includes information published by Alcatel-Lucent's Customer Support group.

- *Release Notes*

Includes critical Open Problem Reports, feature exceptions, and other important information on the features supported in the current release and any limitations to their support.

Technical Support

A service agreement brings your company the assurance of 7x24 no-excuses technical support. You'll also receive regular software updates to maintain and maximize your product's features and functionality and on-site hardware replacement through our global network of highly qualified service delivery partners.

With 24-hour access to the Service and Support web page, you'll be able to view and update any case (open or closed) that you have reported to technical support, open a new case or access helpful release notes, technical bulletins, and manuals.

Access additional information can be found below:

Web: myportal.al-enterprise.com

Phone: 1-800-995-2696

Email: ebg_global_supportcenter@al-enterprise.com

1 OmniSwitch 6465

Refer to the information below for OmniSwitch 6465 models and components.

Model Number	Description
OS6465-P6	Fixed-configuration, fanless, din-mountable chassis with: <ul style="list-style-type: none">• 4 - RJ45 10/100/1000Base-T 802.3at PoE ports (Odd-numbered ports support 60W/802.3bt)• 2- 100/1000Base-X SFP ports
OS6465-P12	Fixed-configuration, fanless, din-mountable chassis with: <ul style="list-style-type: none">• 8 - RJ45 10/100/1000Base-T 802.3at PoE ports (Odd-numbered ports support 60W/802.3bt)• 4- 100/1000Base-X SFP ports
OS6465-P12 (ENH-240)	Fixed-configuration, fanless, din-mountable chassis with increased PoE budget: <ul style="list-style-type: none">• 8 - RJ45 10/100/1000Base-T 802.3at PoE ports (Odd-numbered ports support 60W/802.3bt)• 4- 100/1000Base-X SFP ports
OS6465-P28	Fixed-configuration, fanless, rack-mountable chassis in a 1U form factor with: <ul style="list-style-type: none">• 22 - RJ45 10/100/1000Base-T 802.3at PoE ports (Ports 1 - 8 support 60W/802.3bt)• 2- 100/1000Base-X SFP ports• 4- SFP+ 1G/10G ports
OS6465T-12	Fixed-configuration chassis with: <ul style="list-style-type: none">• 8 - RJ45 10/100/1000Base-T ports• 2 - 10/100/1000Base-T or 100/1000Base-X Combo ports• 2- 1000Base-X SFP ports
OS6465T-P12	Fixed-configuration with: <ul style="list-style-type: none">• 8 - RJ45 10/100/1000Base-T 802.3at PoE ports• 2 - 10/100/1000Base-T or 100/1000Base-X Combo ports• 2- 100/1000Base-X SFP ports

Note: The 'T' models support an increased operating temperature range as documented in the chassis specifications table, but they do not meet the Industrial Compliance Requirements listed in the Standards Compliance section.

OmniSwitch 6465 Availability Features

The switch provides a broad variety of availability features. Availability features are hardware and software-based safeguards that help prevent the loss of data flow in the unlikely event of a subsystem failure. In addition, some availability features allow users to maintain or replace hardware components without powering off the switch or interrupting switch operations. Combined, these features provide added resiliency and help ensure that the switch is consistently available for day-to-day network operations.

Hardware-related availability features include:

- [Power Supply Redundancy](#)
- [Hot-Swapping](#)
- [Hardware Monitoring](#)

Power Supply Redundancy

Multiple power supplies can be used for power supply redundancy. Only the OmniSwitch 6465-P28 supports power supply load sharing for Power over Ethernet, other models support power supply redundancy only. For information on power supplies, refer to [Chapter 3, “Chassis and Power Supplies.”](#) For information on Power over Ethernet, refer to [“Managing Power over Ethernet \(PoE\)”](#).

Hot-Swapping

Hot-swapping refers to the action of adding, removing, or replacing certain hardware components without powering off your switch and disrupting other components in the chassis. This feature greatly facilitates hardware upgrades and maintenance and also allows you to easily replace components in the unlikely event of hardware failure.

Hardware Monitoring

Automatic Monitoring

Automatic monitoring refers to the switch’s built-in sensors that automatically monitor operations. If an error is detected (e.g., over-threshold temperature), the switch immediately sends a trap to the user. The trap is displayed on the console in the form of a text error message.

LEDs

LEDs, which provide visual status information, are provided on the front and rear panels. LEDs are used to indicate conditions, such as hardware and software status, link integrity, data flow, etc. For detailed LED descriptions, refer to the corresponding hardware component section in the next chapter.

User-Driven Monitoring

User-driven hardware monitoring refers to CLI commands that are entered by the user in order to access the current status of hardware components. The user enters “show” commands that output information to the console. The show commands for all the features are described in detail in the *OmniSwitch CLI Reference Guide*.

2 Getting Started

Installing the Hardware

Note. For information on configuring a Virtual Chassis (VC), refer to the *OmniSwitch AOS Release 8 Switch Management Guide*.

Items Required

- Grounding wrist strap
- Phillips screwdriver
- Flat-blade screwdriver

Site Preparation

Environmental Requirements

The switches have the following environmental and airflow requirements:

- The installation site must maintain a supported temperature and humidity range as given in the specifications table for the chassis. See [“OmniSwitch 6465 Chassis Details”](#) on page 3-2.
- Be sure to allow adequate room for proper air ventilation around the chassis. Refer to [“Mounting the Switch”](#) on page 3-18 for minimum clearance requirements.

Electrical Requirements

Note. Switches must be installed by a professional installer. It is the responsibility of the installer to ensure that proper grounding is available and that the installation meets applicable local and national electrical codes.

The switches have the following general electrical requirements:

- Each switch requires one grounded electrical outlet for each power supply installed in the chassis.

Redundant AC Power. It is recommended that each AC outlet resides on a separate circuit. With redundant AC, if a single circuit fails, the switch’s remaining power supplies (on separate circuits) can remain operational.

Electrical Surge Warning

In order to help protect equipment against electrical surges please take note of the following recommendations and guidelines:

- 1** Earth grounding of all devices is fundamental to ensure long term reliability.
 - All electrical equipment must be installed by a qualified, licensed electrician.
 - Every power supply that is connected to building power should be earth grounded.
 - Earth grounding for the power cable, should be verified to be 0.01 ohm or less.
 - Each switch should be grounded to same earth ground as the power supply.
 - Each powered device, such as an AP or camera, should be connected to earth ground.
 - Each surge suppression device should be connected to earth ground.

- 2** Shielded cables (STP) offer some minimal level of additional protection over unshielded Ethernet cables (UTP) but the use of a surge protector is still recommended.
 - It is suggested to use STP Cat5e or better for 1Gbps Ethernet switches for any outdoor application or applications where Ethernet cables come in close proximity to alternating current conductors.
 - Always install cables according to manufacturer requirements.

- 3** For any connections where integrity of the cabling within a building ground is questionable (i.e outdoor connections), copper Ethernet ports must be connected with an appropriate surge protection device, inline, between the PSE and PD per the manufacturer's recommendations for connection and grounding.

- 4** Caution should be taken for any cable connected to any outdoor device, not only on the device grounding, but to ensure that any outdoor device cables that could carry surge currents, do not pass those surge currents to upstream Ethernet switches.

- 5** Caution - Category 5e, Category 6, and Category 6a cables can store large amounts of static electricity due to the dielectric properties of their construction materials in addition, this build up of electricity could lead to a Cable Discharge Event (CDE). A CDE can occur due to the differential in charges on the cable and the equipment it's being connected to. It is recommended that installers momentarily ground all copper Ethernet cables (especially in new cable runs) to a suitable and safe earth ground before connecting them to the port.

Note. Failure to follow the above recommendations could result in voiding the warranty of the affected ALE product.

Unpacking and Installing the Switch

To protect your switch components from damage, read all unpacking recommendations and instructions carefully before beginning.

Unpack your chassis as close as possible to the location where it will be installed.

Items Included

Your OmniSwitch may include the following items:

- OmniSwitch chassis with power supplies, per order
- Transceivers, per order
- Blank cover panel
- Rack mount brackets
- Country-specific power cord(s)
- Rubber table-mounting feet
- Attachment screws
- Assorted instructional cards, anti-static bags and additional packaging

Weight Considerations

Weights vary depending on model type. Please refer to the chassis specifications table.

Connections and Cabling

Once your switch is properly installed, you should connect all network and management cables required for your network applications. Connections may include:

- Console connector
- Cables to NIs or transceivers

Network Cable Installation Warning

Never install exposed network cables outdoors. Install network cables per manufacturer requirements.

Serial Connection to the Console Port

The console port provides a serial connection to the switch is required when logging into the switch for the first time. By default, this connector provides a DCE console connection.

Serial Connection Default Settings

baud rate	9600
parity	none
data bits (word size)	8
stop bits	1

For information on modifying these settings, refer to the *Switch Management Guide*.

Booting the Switch

Now that you have installed the switch components and connected network and management cables, you can boot the switch. To boot the switch, plug all power supply cords into easily-accessible, properly grounded power outlets. (Do not use extension cords.) The switch will power on and boot automatically.

Note. If you have more than one power supply installed, be sure to plug in each power supply in rapid succession, (i.e., within a few seconds of each other). This ensures that there will be adequate power for all components throughout the boot process.

Component LEDs

During the boot process, component LEDs will flash and change color, indicating different stages of the boot. For complete information on LED states, refer to [“Chassis Status LEDs” on page 3-17](#).

Once the switch has completely booted and you have accessed your computer’s terminal emulation software via the console port, you are ready to log in to the switch’s Command Line Interface (CLI) and configure basic information. Continue to [“Your First Login Session” on page 2-6](#).

Your First Login Session

In order to complete the setup process for the switch, you must complete the following steps during your first login session:

- Log in to the switch
- Unlock session types
- Change the login password
- Set the date and time
- Set optional system information
- Save your changes

Important. You must be connected to the switch via the console port before initiating your first login session.

Logging In to the Switch

When you first log in to the switch, you will be prompted for a login name and password. Use the switch's default settings:

- Login: **admin**
- Password: **switch**

The default welcome banner, which includes information such as the current software version and system date, is displayed followed by the CLI command prompt:

```
Welcome to the Alcatel-Lucent Enterprise OmniSwitch 8.5.R01, February 15, 2018.
```

```
Copyright (c) ALE-USA Inc., 2014-2021. All Rights Reserved.
```

```
OmniSwitch(tm) is a trademark of Alcatel-Lucent, registered in the United States  
Patent and Trademark Office.
```

```
->
```

Note. A user account includes a login name, password, and user privileges. Privileges determine whether the user has read or write access to the switch and which commands the user is authorized to execute. For detailed information on setting up and modifying user accounts, refer to the *Switch Management Guide*.

Unlocking Session Types

Security is a key feature on an OmniSwitch switch. As described on [page 2-6](#), when you access the switch for the first time, you must use a *direct console port connection*. All other session types (Telnet, FTP, WebView, and SNMP) are locked out until they are manually unlocked by the user.

The CLI command used to unlock session types is **aaa authentication**.

Note. When you unlock session types, you are granting switch access to non-local sessions (e.g., Telnet). As a result, users who know the correct user login and password will have remote access to the switch. For more information on switch security, refer to the *Switch Management Guide*.

Unlocking All Session Types

To unlock all session types, enter the following command syntax at the CLI prompt:

```
-> aaa authentication default local
```

Unlocking Specified Session Types

You can also unlock session types on a one-by-one basis. For example, to unlock Telnet sessions only, enter the following command:

```
-> aaa authentication telnet local
```

To unlock WebView (HTTP) sessions only, enter the following command:

```
-> aaa authentication http local
```

You cannot specify more than one session type in a single command line. However, you can still unlock multiple session types by using the **aaa authentication** command in succession. For example:

```
-> aaa authentication http local
-> aaa authentication telnet local
-> aaa authentication ftp local
```

Refer to the *OmniSwitch CLI Reference Guide* for complete **aaa authentication** command syntax options.

Changing the Login Password

Change the login password for **admin** user sessions by following the steps below:

- 1** Be sure that you have logged into the switch as user type **admin** (see [“Logging In to the Switch” on page 2-6](#)).
- 2** Enter the keyword **password** and press **Enter**.
- 3** Enter your new password at the prompt.

Note. Be sure to remember or securely record all new passwords; overriding configured passwords on an OmniSwitch is restricted.

- 4** You will be prompted to re-enter the password. Enter the password a second time.

New password settings are automatically saved in real time to the local user database; the user is not required to enter an additional command in order to save the password information. Also note that new password information is retained following a reboot. All subsequent login sessions, including those through the console port, will require the new password to access the switch.

For detailed information on managing login information, including user names and passwords, refer to the *Switch Management Guide*.

Setting the System Time Zone

The switch's default time zone is UTC. If you require a time zone that is specific to your region, or if you need to enable Daylight Savings Time (DST) on the switch, you can configure these settings via the **system timezone** and **system daylight-savings-time** commands.

For detailed information on configuring a time zone for the switch, refer to the *Switch Management Guide*.

Setting the Date and Time

Set the current time for the switch by entering **system time**, followed by the current time in *hh:mm:ss*.

To set the current date for the switch, enter **system date**, followed by the current date in *mm/dd/yyyy*.

Setting Optional Parameters

Specifying an Administrative Contact

An administrative contact is the person or department in charge of the switch. If a contact is specified, users can easily find the appropriate network administrator if they have questions or comments about the switch.

To specify an administrative contact, use the **system contact** command.

Specifying a System Name

The system name is a simple, user-defined text description for the switch. To specify a system name, use the **system name** command.

Specifying the Switch's Location

It is recommended that you use a physical labeling system for locating and identifying your switch(es). Examples include placing a sticker or placard with a unique identifier (e.g., the switch's default IP address) on each chassis.

However, if no labeling system has been implemented or if you need to determine a switch's location from a remote site, entering a system location can be very useful.

To specify a system location, use the **system location** command.

Viewing Your Changes

To view your current changes, enter **show system** at the CLI prompt.

Saving Your Changes

Once you have configured this basic switch information, save your changes by entering **write memory** at the CLI command prompt.

3 Chassis and Power Supplies

This chapter includes detailed information on the chassis types. Topics include:

- Chassis details and technical specifications:
 - OS6465-P6, [page 3-2](#).
 - OS6465-P12, [page 3-5](#).
 - OS6465-P12 (ENH-240), [page 3-8](#).
 - OS6465-P28, [page 3-11](#).
 - OS6465T-12, [page 3-13](#).
 - OS6465T-P12, [page 3-15](#).
- Mounting the Switch, [page 3-18](#).
- Power supplies, [page 3-27](#).
 - OS6465-BPN-X, [page 3-31](#).
 - OS6465-BPN-H, [page 3-32](#).
 - OS6465-BPN, [page 3-33](#).
 - OS6465-BPR, [page 3-34](#).
 - OS6465-BPRD, [page 3-35](#).
 - Internal Power Supplies, [page 3-36](#).
- Alarm Relays, [page 3-42](#).
- Temperature management, [page 3-44](#).
- Monitoring the chassis components via the Command Line Interface (CLI), [page 3-44](#)

OmniSwitch 6465 Chassis Details

OS6465-P6

OS6465-P6 Front Panel

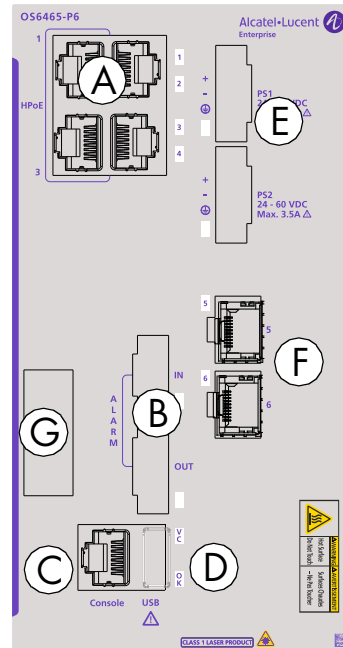

Item	Description
A	(1-4) 10/100/1000Base-T 802.3at PoE ports (Odd-numbered ports support 60W/802.3bt)
B	Alarm Connectors
C	Console port
D	USB port
E	Power Supply Connectors
F	(5-6) 100/1000Base-X SFP ports
G	Grounding Lug
LEDs	See “Chassis Status LEDs” on page 3-17

CLASS 1 M LASER CAUTION. CAUTION - CLASS 1 M LASER RADIATION WHEN OPEN. DO NOT VIEW DIRECTLY WITH OPTICAL INSTRUMENTS

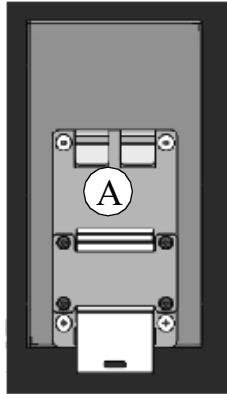
OS6465-P6 Rear Panel

Item	Description
A	DIN Mounting Bracket

OS6465-P6 Chassis Specifications

Chassis Height	15 cm (5.91 in.)
Chassis Width	8 cm (3.15 in.)
Chassis Depth	15 cm (5.91 in.)
Chassis Weight	1.22 kg (2.69 lb)
Ambient Operating Temperature (Tmra)	-40°C to 75°C (-40°F to 167°F)
Internal Temperature Range (internal)	-45°C to 93°C (-49°F to 199°F)
Warning Threshold (<i>Thresh</i>) (internal)	93°C (199°F)
Danger Threshold (internal)	94°C (201°F)
Storage Temperature	-40°C to 85°C (-40°F to 185°F)
Operating Humidity	5% to 95% non-condensing
Storage Humidity	5% to 95% non-condensing
Power Consumption (idle)	16W
Input Power & Current	24-60Vdc, max. 3.5A
Input Range	50 - 57V: (3.5A), 150W max, PoE 802.3AT 44 - 57V: (3.5A), 120W max, PoE 802.3 AF 24 - 60V: (1.5A), Non-PoE, system only

OS6465-P6 can be powered by a 24V DC input for non-POE applications. Currently an issue with the detection circuitry prevents the configuration of a power supply with 24V output on the switch, and doesn't allow the PS LEDs to be turned on. This issue will be fixed in a future hardware release.

When connecting an OS6465-P6 in dual-redundant power supply configuration, both power supplies must have identical output wattage and identical nominal output voltage. Use of dissimilar power supplies could result in unexpected behavior and is not supported.

***Note On Chassis Versus Ambient Temperatures.** Internal temperature refers to the sensor reading of the internal switch temperature. Ambient temperature (Tmra) refers to the approximate room temperature. The ambient temperature will typically be lower than the internal temperature.

OS6465-P12

OS6465-P12 Front Panel

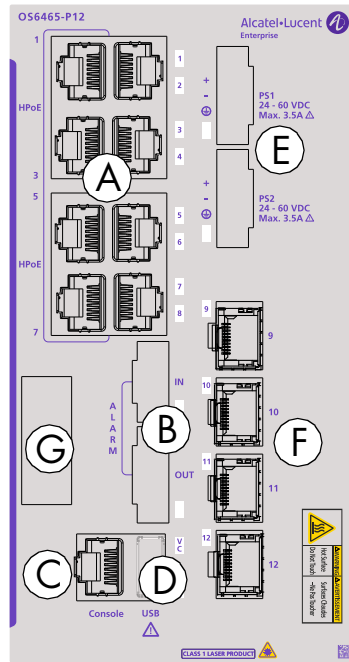

Item	Description
A	(1-8) 10/100/1000Base-T 802.3at PoE ports (Odd-numbered ports support 60W/802.3bt)
B	Alarm Connectors
C	Console port
D	USB port
E	Power Supply Connectors
F	(9-12) 100/1000Base-X SFP ports
G	Grounding Lug
LEDs	See “Chassis Status LEDs” on page 3-17

CLASS 1 M LASER CAUTION. CAUTION - CLASS 1 M LASER RADIATION WHEN OPEN. DO NOT VIEW DIRECTLY WITH OPTICAL INSTRUMENTS

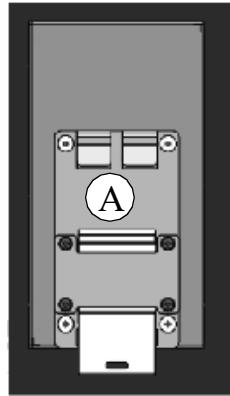
OS6465-P12 Rear Panel

Item	Description
A	DIN Mounting Bracket

OS6465-P12 Chassis Specifications

Chassis Height	15 cm (5.91 in.)
Chassis Width	8 cm (3.15 in.)
Chassis Depth	15 cm (5.91 in.)
Chassis Weight	1.29 kg (2.84 lb)
Ambient Operating Temperature (T _{mra})	-40°C to 75°C (-40°F to 167°F)
Internal Temperature Range (internal)	-45°C to 95°C (-49°F to 203°F)
Warning Threshold (<i>Thresh</i>) (internal)	95°C (203°F)
Danger Threshold (internal)	97°C (207°F)
Storage Temperature	-40°C to 85°C (-40°F to 185°F)
Operating Humidity	5% to 95% non-condensing
Storage Humidity	5% to 95% non-condensing
Power Consumption (idle)	18W
Input Power & Current	24-60Vdc, max. 3.5A
Input Range	50 - 57V: (3.5A), 150W max, PoE 802.3AT 44 - 57V: (3.5A), 120W max, PoE 802.3 AF 24 - 60V: (1.5A), Non-PoE, system only

OS6465-P12 can be powered by a 24V DC input for non-POE applications. Currently an issue with the detection circuitry prevents the configuration of a power supply with 24V output on the switch, and doesn't allow the PS LEDs to be turned on. This issue will be fixed in a future hardware release.

When connecting an OS6465-P12 in dual-redundant power supply configuration, both power supplies must have identical output wattage and identical nominal output voltage. Use of dissimilar power supplies could result in unexpected behavior and is not supported.

***Note On Chassis Versus Ambient Temperatures.** Internal temperature refers to the sensor reading of the internal switch temperature. Ambient temperature (T_{mra}) refers to the approximate room temperature. The ambient temperature will typically be lower than the internal temperature.

OS6465-P12 (ENH-240)

OS6465-P12 (ENH-240) Front Panel

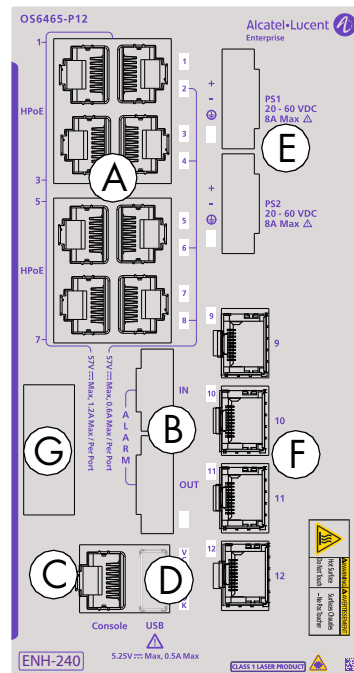

Item	Description
A	(1-8) 10/100/1000Base-T 802.3at PoE ports (Odd-numbered ports support 60W/802.3bt)
B	Alarm Connectors
C	Console port
D	USB port
E	Power Supply Connectors
F	(9-12) 100/1000Base-X SFP ports
G	Grounding Lug
LEDs	See “Chassis Status LEDs” on page 3-17

CLASS 1 M LASER CAUTION. CAUTION - CLASS 1 M LASER RADIATION WHEN OPEN.
DO NOT VIEW DIRECTLY WITH OPTICAL INSTRUMENTS

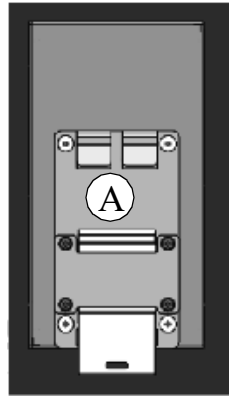
OS6465-P12 (ENH-240) Rear Panel

Item	Description
A	DIN Mounting Bracket

OS6465-P12 (ENH-240) Chassis Specifications

Chassis Height	15 cm (5.91 in.)
Chassis Width	8 cm (3.15 in.)
Chassis Depth	15 cm (5.91 in.)
Chassis Weight	1.29 kg (2.84 lb)
Ambient Operating Temperature (T _{mra})	-40°C to 75°C (-40°F to 167°F)
Internal Temperature Range (internal)	-45°C to 84°C (-49°F to 183°F)
Warning Threshold (<i>Thresh</i>) (internal)	84°C (183°F)
Danger Threshold (internal)	89°C (192°F)
Storage Temperature	-40°C to 85°C (-40°F to 185°F)
Operating Humidity	5% to 95% non-condensing
Storage Humidity	5% to 95% non-condensing
Power Consumption (idle)	20W
Input Power & Current	20-60Vdc, max. 10A
Input Range	50-57V: (10A), 240W max, PoE 802.3AT 50 - 57V: (3.5A), 150W max, PoE 802.3AT 44 - 57V: (3.5A), 120W max, PoE 802.3AF 24 - 60V: (1.5A), Non-PoE, system only

When connecting in dual-redundant power supply configuration, both power supplies must have identical output wattage and identical nominal output voltage. Use of dissimilar power supplies could result in unexpected behavior and is not supported.

***Note On Chassis Versus Ambient Temperatures.** Internal temperature refers to the sensor reading of the internal switch temperature. Ambient temperature (T_{mra}) refers to the approximate room temperature. The ambient temperature will typically be lower than the internal temperature.

OS6465-P28

OS6465-P28 Front Panel

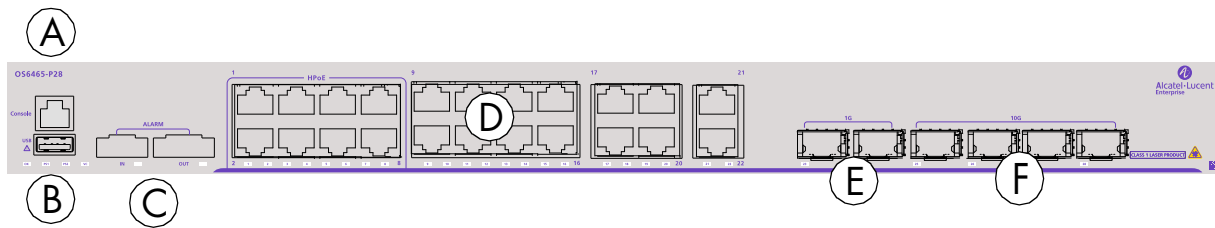

Item	Description
A	Console port
B	USB port
C	Alarm Connectors
D	(1-22) 10/100/1000Base-T PoE 802.3at ports (ports 1-8 support 60W/802.3bt)
E	(23-24) 100/1000Base-X SFP ports
F	(25-28) 1G/10G SFP+ ports
LEDs	See “Chassis Status LEDs” on page 3-17

CLASS 1 M LASER CAUTION. CAUTION - CLASS 1 M LASER RADIATION WHEN OPEN.
DO NOT VIEW DIRECTLY WITH OPTICAL INSTRUMENTS

OS6465-P28 Rear Panel



Item	Description
A	Grounding Lug
B	Power Supply Connectors

OS6465-P28 Chassis Specifications

Chassis Height	4.4 cm (1.73 in)
Chassis Width	44 cm (17.33 in)
Chassis Depth	27 cm (1.06. in)
Chassis Weight (without power supplies)	5.82 kg (12.82 lb)
Power Consumption (idle)	35W
Ambient Operating Temperature (Tmra)	-40°C to 75°C (-40°F to 167°F) With DNV Power Supply Cover: -40°C to 55 °C (-40°F to 131°F)
Internal Temperature Range (internal)	-45°C to 80°C (-49°F to 176°F)
Warning Threshold (<i>Thresh</i>) (internal)	80°C (176°F)
Danger Threshold (internal)	86°C (187°F)
Storage Temperature	-40°C to 85°C (-40°F to 185°F)
Operating Humidity	5% to 95% non-condensing
Storage Humidity	5% to 95% non-condensing

***Note On Chassis Versus Ambient Temperatures.** Internal temperature refers to the sensor reading of the internal switch temperature. Ambient temperature (Tmra) refers to the approximate room temperature. The ambient temperature will typically be lower than the internal temperature.

OS6465T-12

OS6465T-12 Front Panel

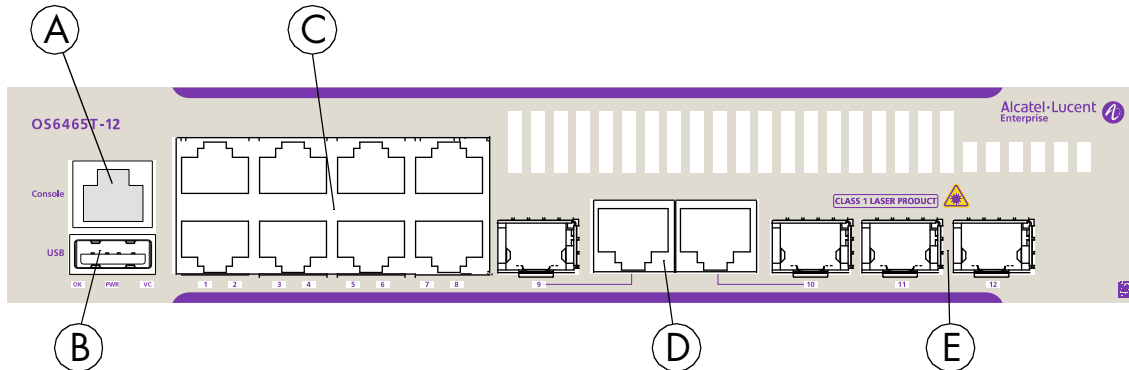

Item	Description
A	Console port
B	USB port
C	(1-8) 10/100/1000Base-T RJ-45 ports
D	(9-10) 10/100/1000Base-T RJ-45 or 100/1000Base-X SFP combo ports
E	(11-12) 1000Base-X SFP ports
LEDs	See “Chassis Status LEDs” on page 3-17

CLASS 1 M LASER CAUTION. CAUTION - CLASS 1 M LASER RADIATION WHEN OPEN.
DO NOT VIEW DIRECTLY WITH OPTICAL INSTRUMENTS

OS6465T-12 Rear Panel

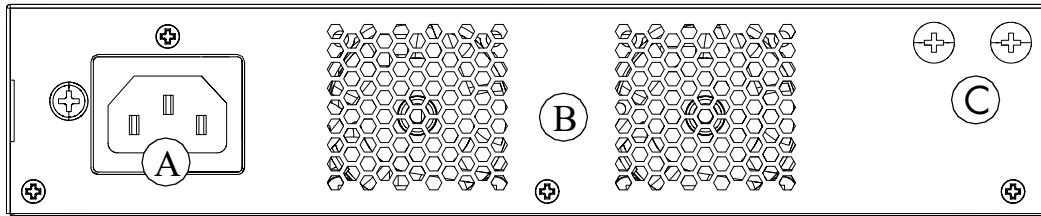

Item	Description
A	Power supply connector
B	Fans
C	Grounding Lug

OS6465T-12 Chassis Specifications

Chassis Height	4.4 cm (1.73 in)
Chassis Width	21.74 cm (8.56 in.)
Chassis Depth	28.07 cm (11.05 in.)
Chassis Weight	1.78 kg (3.92 lb)
Ambient Operating Temperature (T _{mra})	-10°C to 60°C (14°F to 140°F) (fan on) -10°C to 45°C (14°F to 113°F) (fan off) Note: Fan will turn on automatically at 45°C.
Internal Temperature Range (internal)	-15°C to 75°C (5°F to 167°F)
Warning Threshold (<i>Thresh</i>) (internal)	75°C (167°F)
Danger Threshold (internal)	83°C (181°F)
Storage Temperature	-40°C to 85°C (-40°F to 185°F)
Operating Humidity	5% to 95% non-condensing
Storage Humidity	5% to 95% non-condensing
Power Consumption	16W

***Note On Chassis Versus Ambient Temperatures.** Internal temperature refers to the sensor reading of the internal switch temperature. Ambient temperature (T_{mra}) refers to the approximate room temperature. The ambient temperature will typically be lower than the internal temperature.

OS6465T-P12

OS6465T-P12 Front Panel

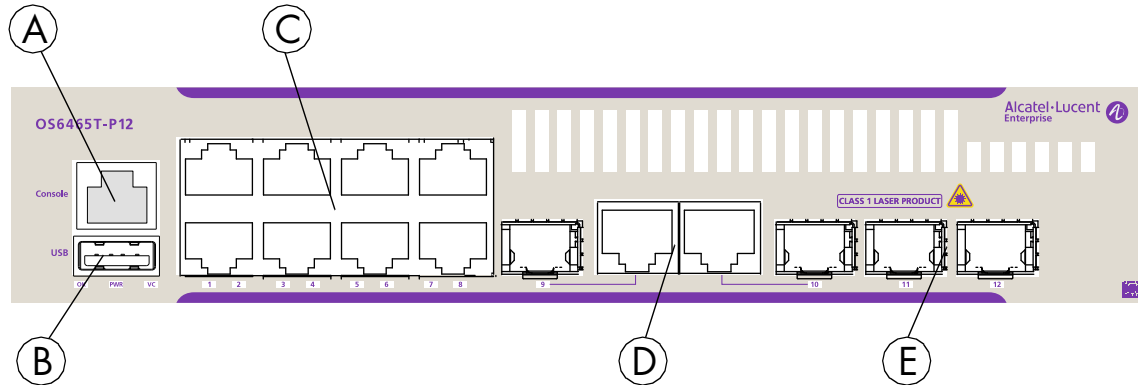

Item	Description
A	Console port
B	USB port
C	(1-8) 10/100/1000Base-T 802.3at PoE RJ-45 ports
D	(9-10) 10/100/1000Base-T RJ-45 (non-Poe) or 100/1000Base-X SFP combo ports
E	(11-12) 1000Base-X SFP ports
LEDs	See “Chassis Status LEDs” on page 3-17

CLASS 1 M LASER CAUTION. CAUTION - CLASS 1 M LASER RADIATION WHEN OPEN.
DO NOT VIEW DIRECTLY WITH OPTICAL INSTRUMENTS

OS6465T-P12 Rear Panel

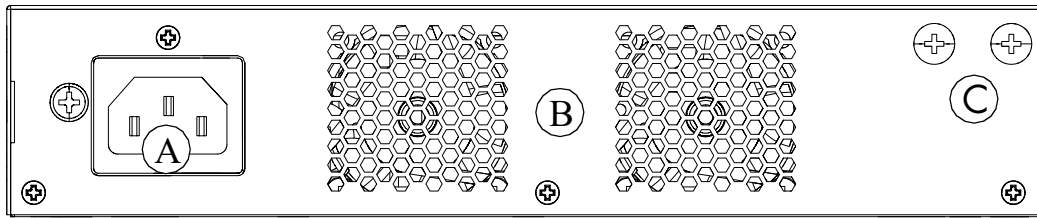

Item	Description
A	Power supply connector
B	Fans
C	Grounding Lug

OS6465T-P12 Chassis Specifications

Chassis Height	4.4 cm (1.73 in.)
Chassis Width	21.74 cm (8.56 in.)
Chassis Depth	28.07 cm (11.05 in.)
Chassis Weight	1.91 kg (4.20 lb)
Ambient Operating Temperature (T _{mra})	-10°C to 60°C (14°F to 140°F) (fan on) -10°C to 45°C (14°F to 113°F) (fan off) Note: Fan will turn on automatically at 45°C.
Internal Temperature Range (internal)	-15°C to 78°C (5°F to 172°F)
Warning Threshold (<i>Thresh</i>) (internal)	78°C (172°F)
Danger Threshold (internal)	85°C (185°F)
Storage Temperature	-40°C to 85°C (-40°F to 185°F)
Operating Humidity	5% to 95% non-condensing
Storage Humidity	5% to 95% non-condensing
Power Consumption	19W

***Note On Chassis Versus Ambient Temperatures.** Internal temperature refers to the sensor reading of the internal switch temperature. Ambient temperature (T_{mra}) refers to the approximate room temperature. The ambient temperature will typically be lower than the internal temperature.

Chassis Status LEDs

The chassis provides a series of status LEDs located on the front panel. These LEDs offer basic status information for hardware operation and port link and activity status.

LED	State	Description
OK	Solid Green	System Diagnostics and AOS bootup OK
	Blinking Green	System Diagnostics and AOS in progress (i.e., performing diagnostics or booting)
	Solid Amber	System Diagnostics and/or AOS bootup failed
VC	Solid Green	This unit is the master unit
	Solid Amber	This unit is a slave unit
	Blinking Amber	Identifies unit number by the number of blinks.
	Off	This unit is in shutdown mode or is not part of a VC.
PS1/PS2	Solid Green	Power supply functioning normally.
	Solid Amber	Power supply not functioning normally.
	Off	Power supply not present.
Alarm In/ Out	Amber	Alarm input or output detected.
	Off	No alarm input or output detected. See “Alarm Relay” on page 3-42.
10/100/1000 Port LEDs	Solid Green	Valid port link (non-PoE)
	Blinking Green	Valid port link with activity (non-PoE)
	Solid Amber	Valid port link (PoE)
	Blinking Amber	Valid port link with activity (PoE)
SFP 100/1000Base-X Port LEDs	Solid Green	Valid port link
	Blinking Green	Valid port link with activity
SFP+ Port LEDs	Solid Green	Valid 1G/10G port link
	Blinking Green	Valid 1G/10G port link with activity

Mounting the Switch

General Mounting Recommendations

Elevated Operating Ambient Temperature. If installed in a closed or multi-rack assembly, the operating ambient temperature of the environment may be greater than the room's ambient temperature. Therefore, consideration should be given to the maximum rated ambient temperature (T_{mra}) listed in the [“OmniSwitch 6465 Chassis Details”](#) section.

Reduced Air Flow. Installation of the equipment should be such that the amount of air flow required for safe operation of the equipment is not compromised. Refer to [“Airflow / Clearance Recommendations”](#) on [page 3-18](#) for more information.

Mechanical Loading. Mounting of the equipment should be such that a hazardous condition is not achieved due to uneven loading.

Circuit Overloading. Consideration should be given to the connection of the equipment to the supply circuit and the effect that overloading of circuits could have on overcurrent protection and supply wiring.

Reliable Earthing. Reliable earthing of equipment should be maintained. Particular attention should be given to supply connections other than direct connections to the branch (e.g., use of power strips).

Airflow / Clearance Recommendations

To ensure proper airflow, be sure that your switch is placed in a clean, well-ventilated area and provide minimum recommended clearance as shown below. Restricted airflow can cause your switch to overheat, which can lead to switch failure. Refer to the following important guidelines:

Minimum Recommended Clearances - P6 / P12 Models

Top (DIN Rail Mount)	N/A - (If no equipment is installed above chassis) 1 inch - (If equipment is installed above chassis).
Bottom (DIN Rail Mount)	N/A - (If no equipment is installed below chassis) 1 inch - (If equipment is installed below chassis).
Sides (DIN Rail Mount)	2 inches
Front / Rear	N/A

Minimum Recommended Clearances - P28 Model

Top	1.75 inch (1RU)
DNV Installations	1.75 inches (1 RU) for OS6465-P28 that requires a DNV power supply cover, operating between -40°C to 55°C (-40°F to 131°F).
Bottom	1.75 inch (1RU)
Sides (DIN Rail Mount)	2 inches
Front / Rear	N/A

DIN Rail Mounting

The OmniSwitch chassis are DIN rail mountable. Refer to the following:

- Hook the top of the DIN rail clip over the top of the DIN rail.
- Rotate assembly downward until the bottom of the DIN rail clip latch snaps in place under the DIN rail and release.

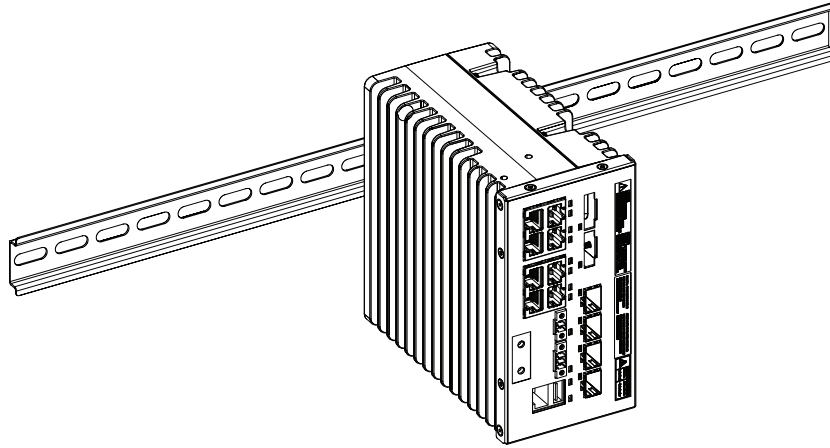

DIN Mounted Chassis

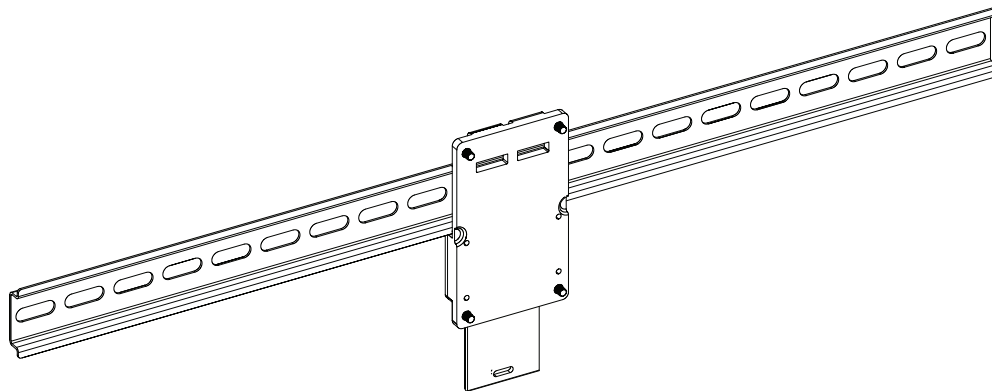

DIN Clip (Chassis Not Shown)

DIN Rail Unmounting

1. Pull down on the DIN rail clip latch to release the bottom. If the latch is hard to reach a long screwdriver or other tool can be used to pull the latch down.
2. Rotate the bottom of the assembly away from the DIN rail and lift the assembly off the DIN rail.

Rack Mounting Steps (Full-width Chassis)

- 1 Attach rack mount brackets to both sides of the chassis as shown.

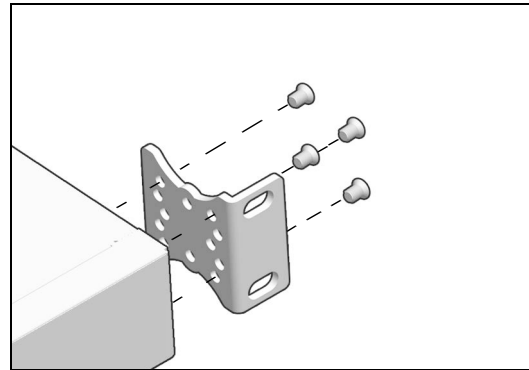
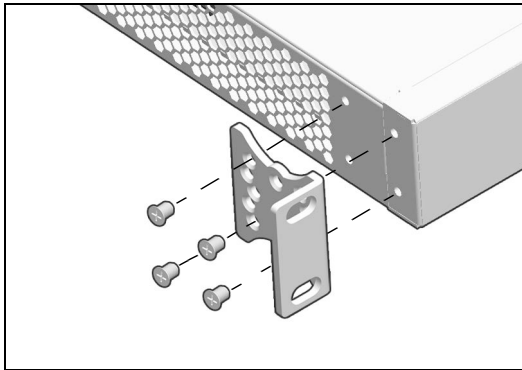

- 2 Mark the holes on the rack where the switch is to be installed.
- 3 Lift and position the switch until the rack-mount brackets are flush with the rack post, then align the holes in the brackets with the rack holes that were marked at step 1.
- 4 Once the holes are aligned, insert a rack mount screw (not provided) through the bottom hole of each bracket. Tighten both screws until they are secure.

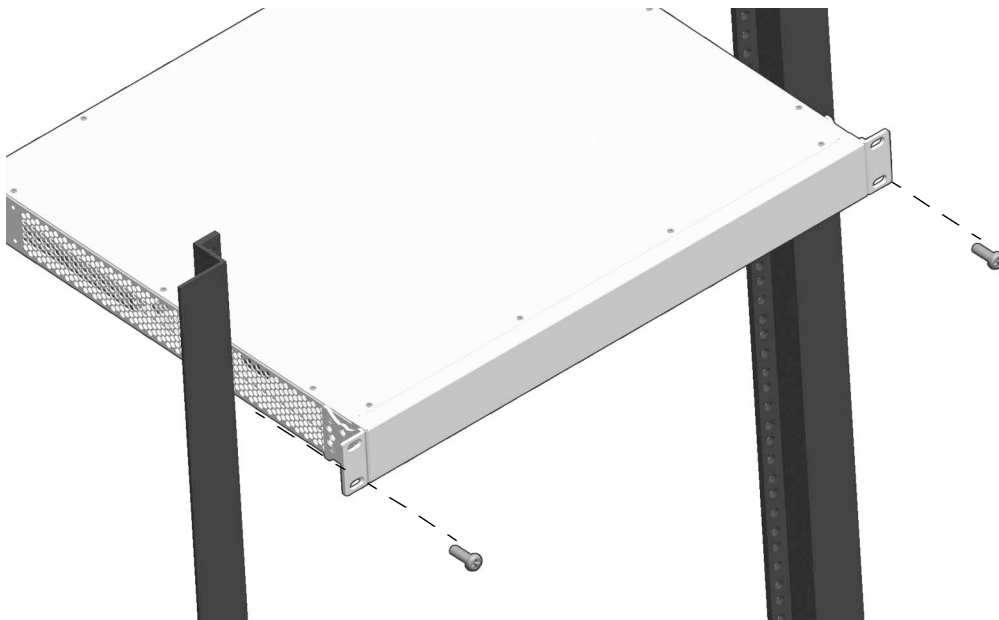

Follow the recommended clearance requirements for the model being mounted.

Note. Be sure to install the screws in the *bottom* hole of each bracket, as shown, before proceeding.

- 5 Once the screws at the bottom of each bracket are secure, install the remaining two rack mount screws. Be sure that all screws are securely tightened.

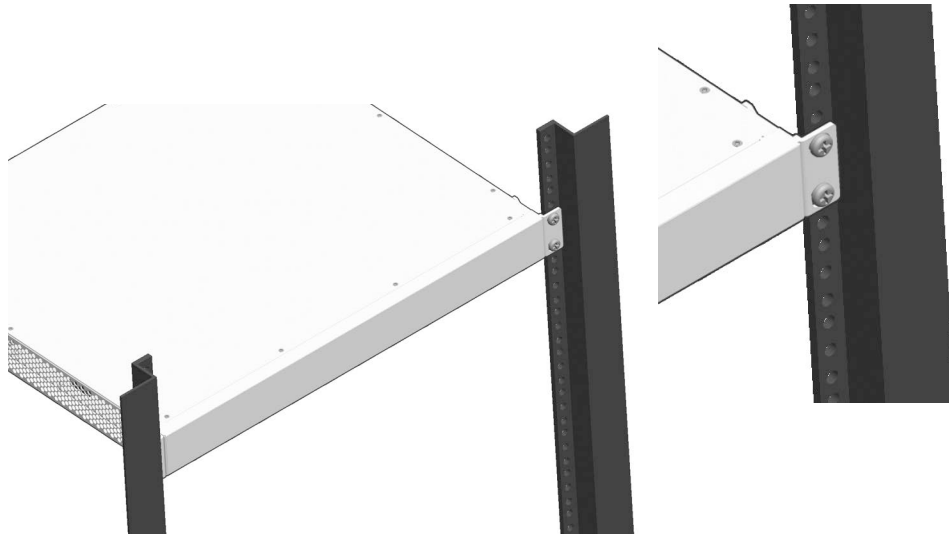

Rack Mounting Steps (One Half-width Chassis - OS6465T-RM-19-L Kit)

A single chassis can also be mounted into a standard 19-inch rack using L-brackets, as shown in the figure below.

- 1 Attach rack mount brackets to both sides of the front of the chassis. The long and short bracket can be mounted on either side of the chassis.

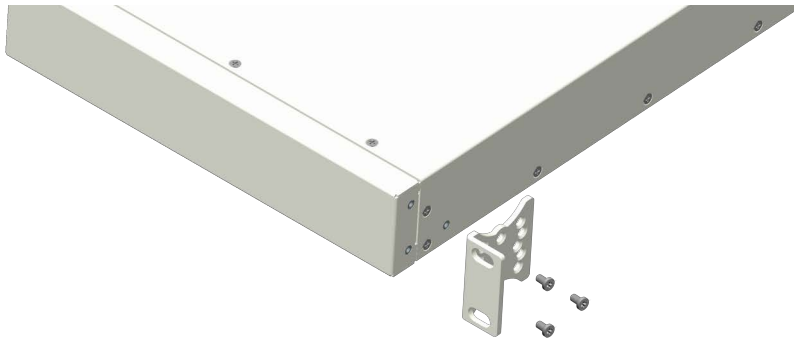

Attach Rack Mount Brackets

- 2 Align the holes in the flanges with the rack holes and insert rack mount screws (not provided) through the *bottom hole of each flange* and then the top of each flange. Tighten both screws until they are secure

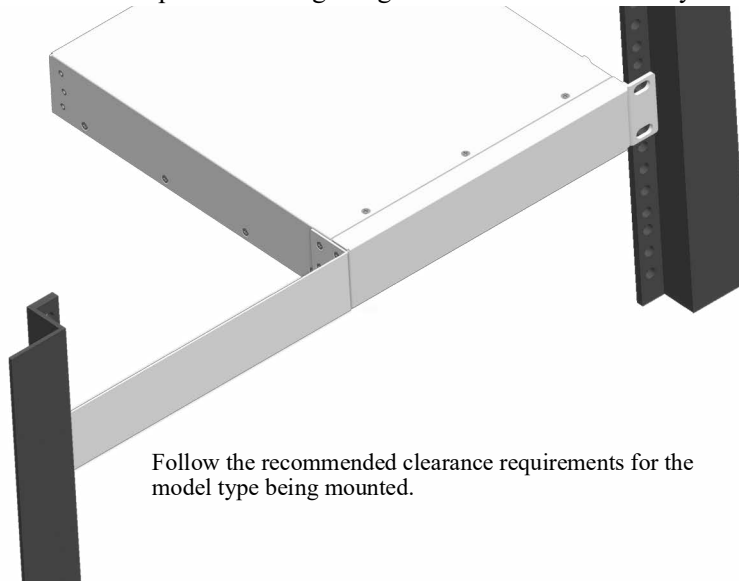

Rack Mounting Steps (Two Half-width Chassis - OS6465T-DUO-MNT Kit)

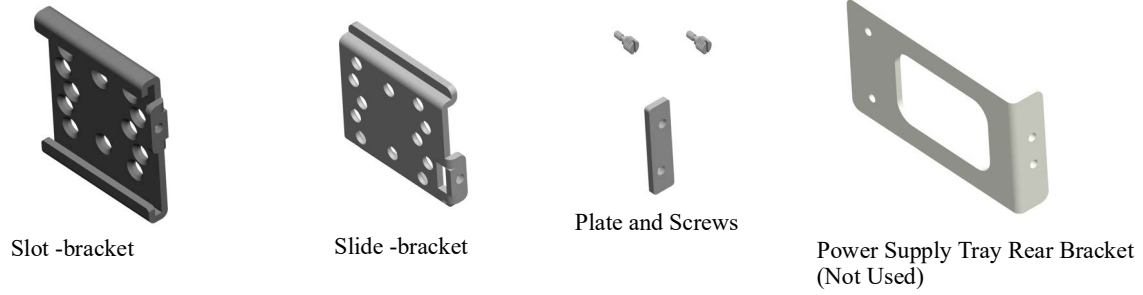

Two chassis can be assembled side-by-side for mounting into a standard 19-inch rack as show in the figure below.

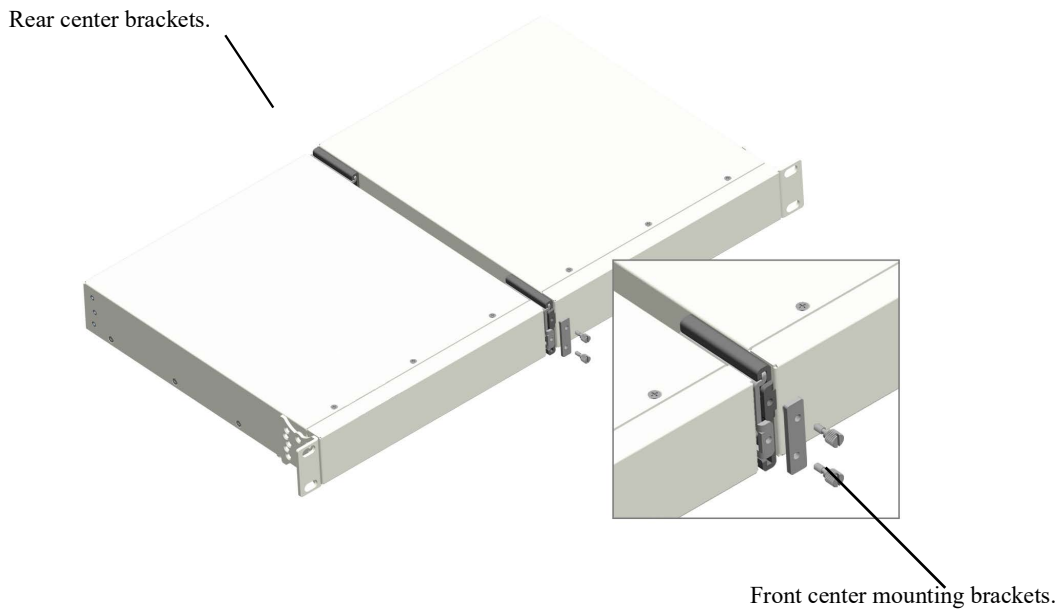

Fully Assembled Side-by-Side Chassis Assembly

1 Attach the slot-brackets and slide-brackets to the front and back of the chassis using the attachment screws (M3 flat head) provided for each bracket.

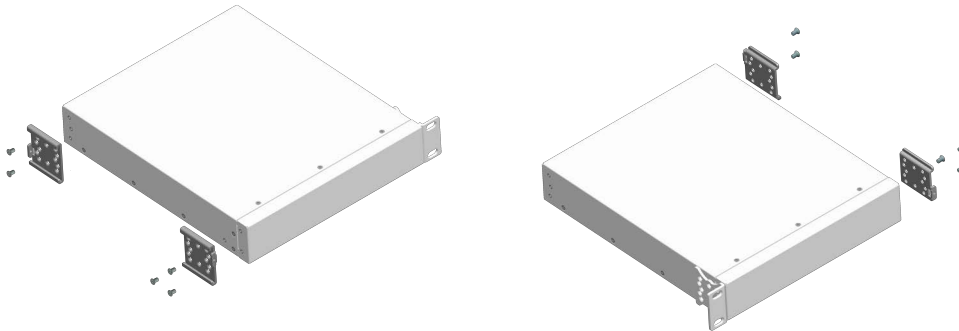

Attach Slot/Slide-Brackets

- 2 Align the chassis and slide both front and rear center brackets together.

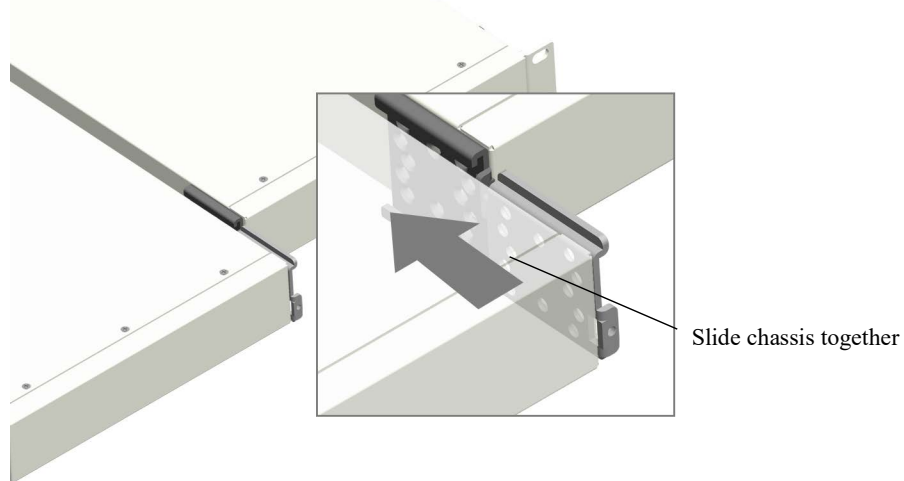

Slide Chassis Together

- 3 Place bracket plate over front and rear brackets and secure with thumb screws.

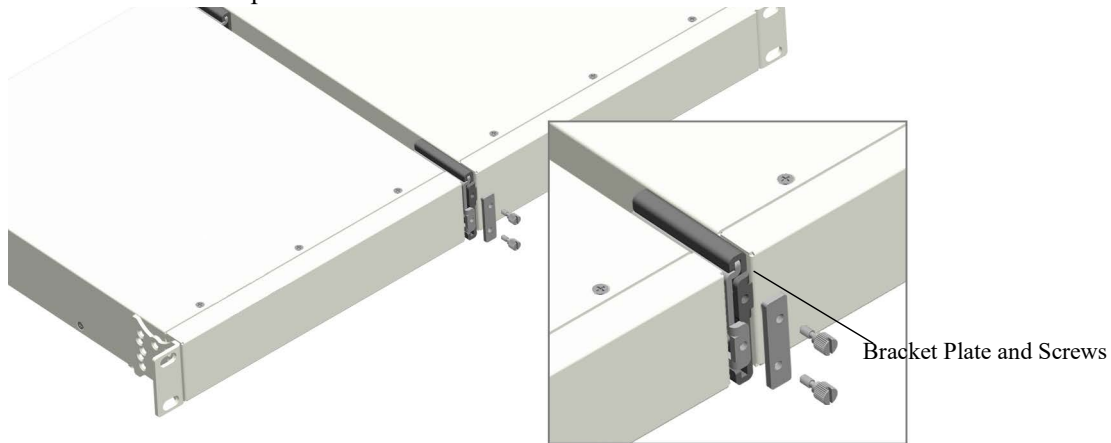

Secure Front and Back with Bracket Plate

- 4 Attach rack mount brackets to both sides of the front of the chassis.

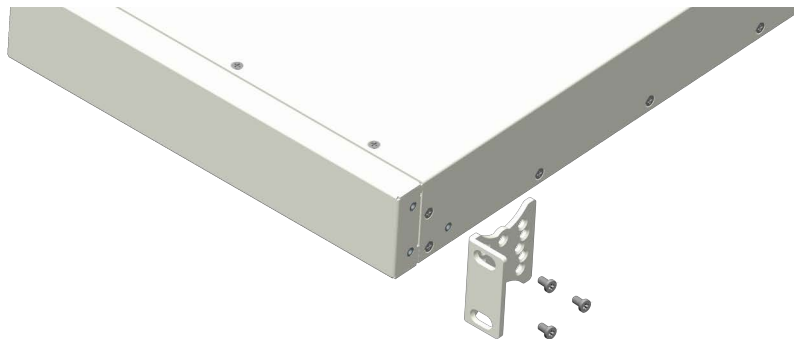

Attach Rack Mount Brackets

- 5 Using one additional person, lift and position the assembly on the rack until the rack-mount flanges are flush with the rack post.

- 6 Align the holes in the flanges with the rack holes and insert rack mount screws (not provided) through the *bottom hole of each flange* and then the top of each flange. Tighten both screws until they are secure.

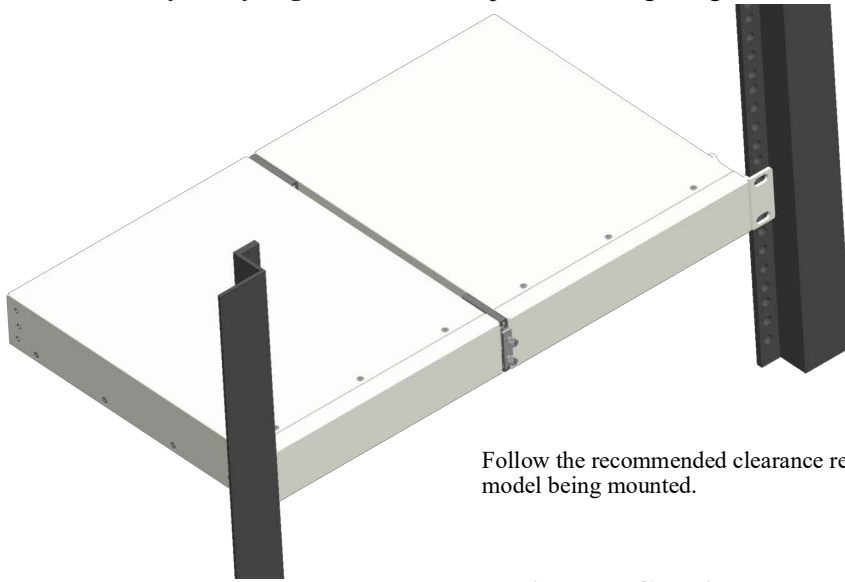

Follow the recommended clearance requirements for the model being mounted.

Rack-mounting Two Chassis

Side Mounting Steps

The OmniSwitch chassis can be side/wall mounted using the OS6465-WALL-MNT (OS6465-WALL-KT5) kit.

- 1 Attach two (2) side brackets using three (3) M4X8MM screws each.

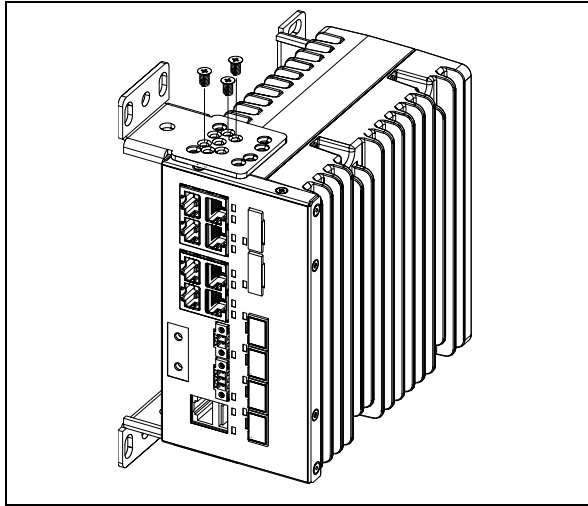

Side Brackets

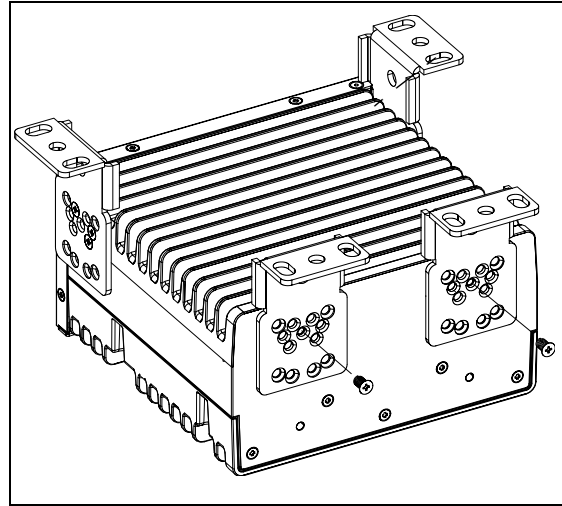

Rear Brackets

- 2 Attach two (2) rear brackets using two (1) M4X8MM screws each.
- 3 Lift and position the switch until the brackets are flush with the mounting surface and mark/align the position of the holes in the brackets on the mounting surface. Drill holes if necessary.
- 4 Secure the four (4) mounting brackets to the mounting surface using two (2) M5X15MM bolts, four (4) washers, and two (2) nuts per bracket.

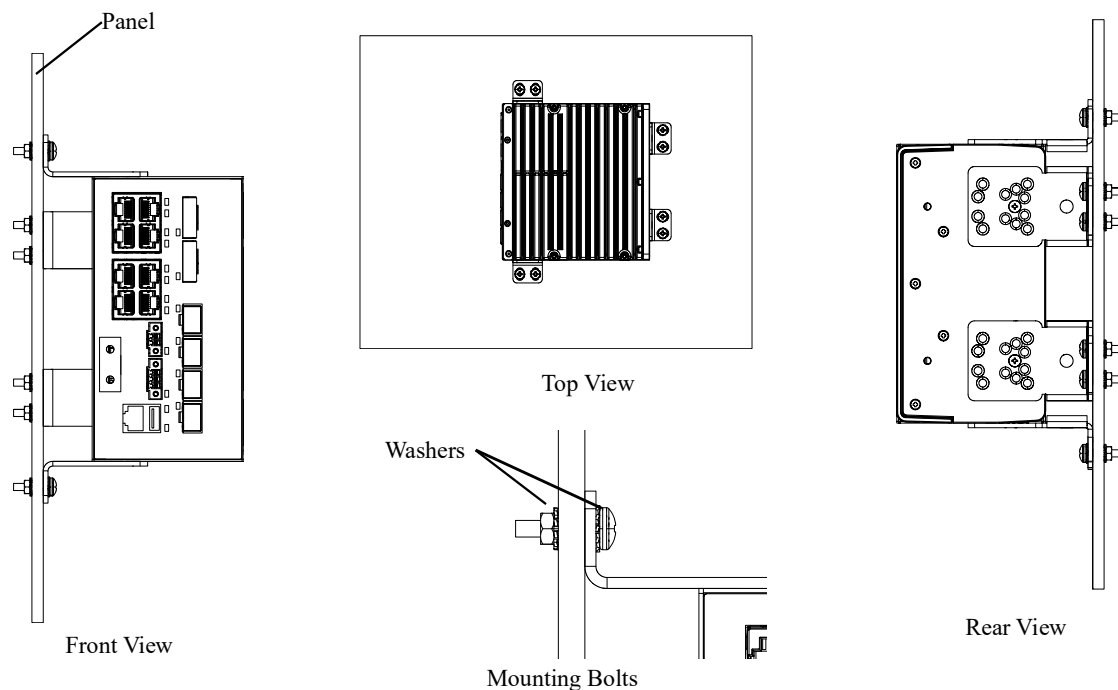

DNV Mounting Steps

The OmniSwitch chassis can be mounted according to DNV standards. The parts required are contained in the **OS6465-REAR-MNT** (brackets) and **OS6465-DNV-RACK** (power supply and tray) kits.

- **OS6465-REAR-MNT** - (2) Side Rails, (2) Rear Brackets, (1) Support Bracket, (18) M4X8MM (Flat)
- **OS6465-DNV-RACK** - (1) Power Supply Tray (182343-10), (1) Power Supply Cover, (1) Filler Bracket, (2) Slider Brackets, (6) M3X6MM (Flat), (4) M3X6MM (Round)

1 Install the Side Rails, Rear Brackets, and Power Supply Tray.

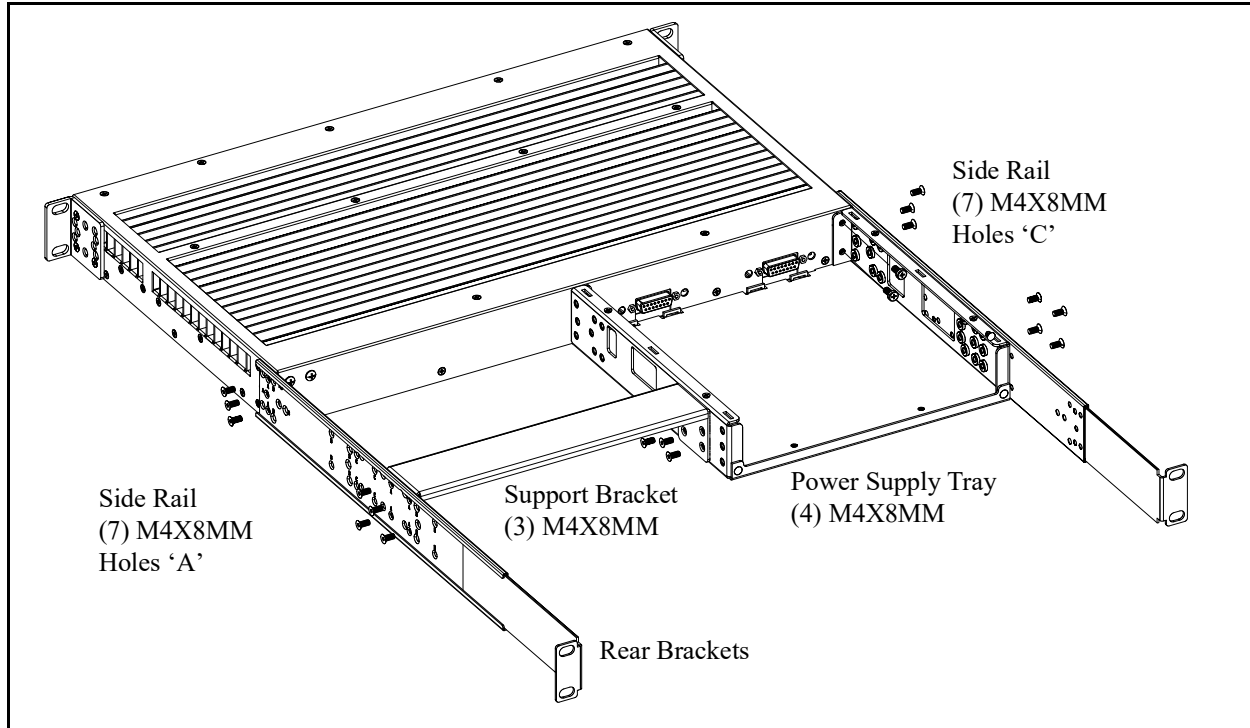

Rails and Power Supply Tray

2 Install Power Supplies.

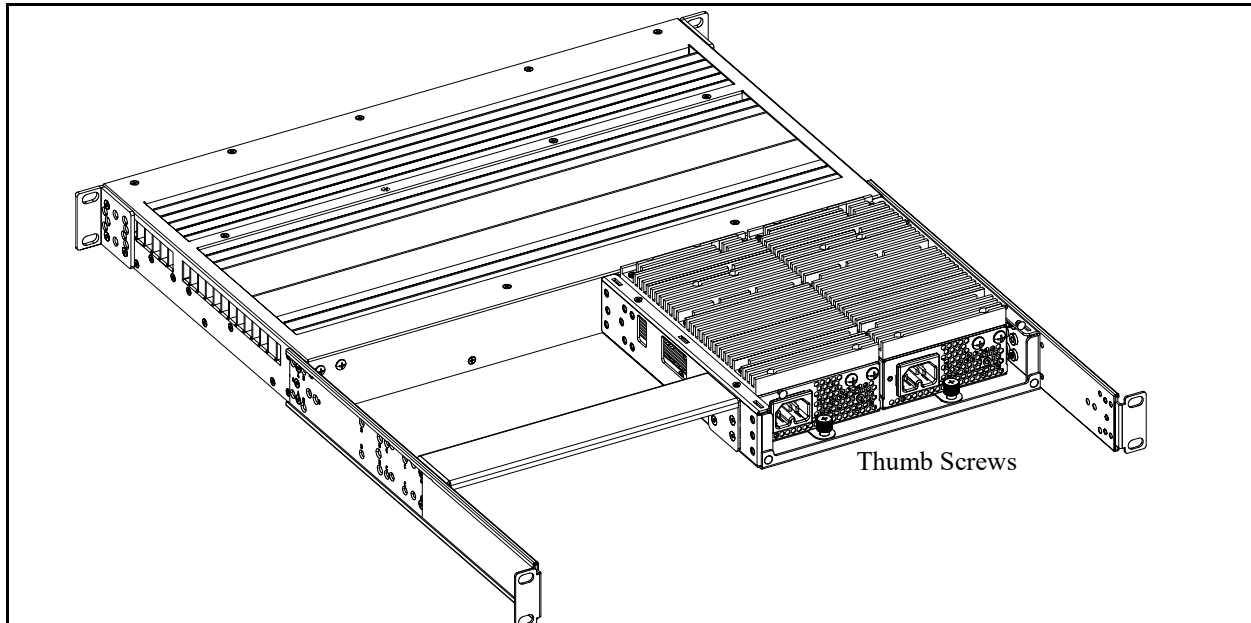

Side Rails, Rear Brackets, and Power Supply Tray with Power Supplies

3 Power Supply Cover.

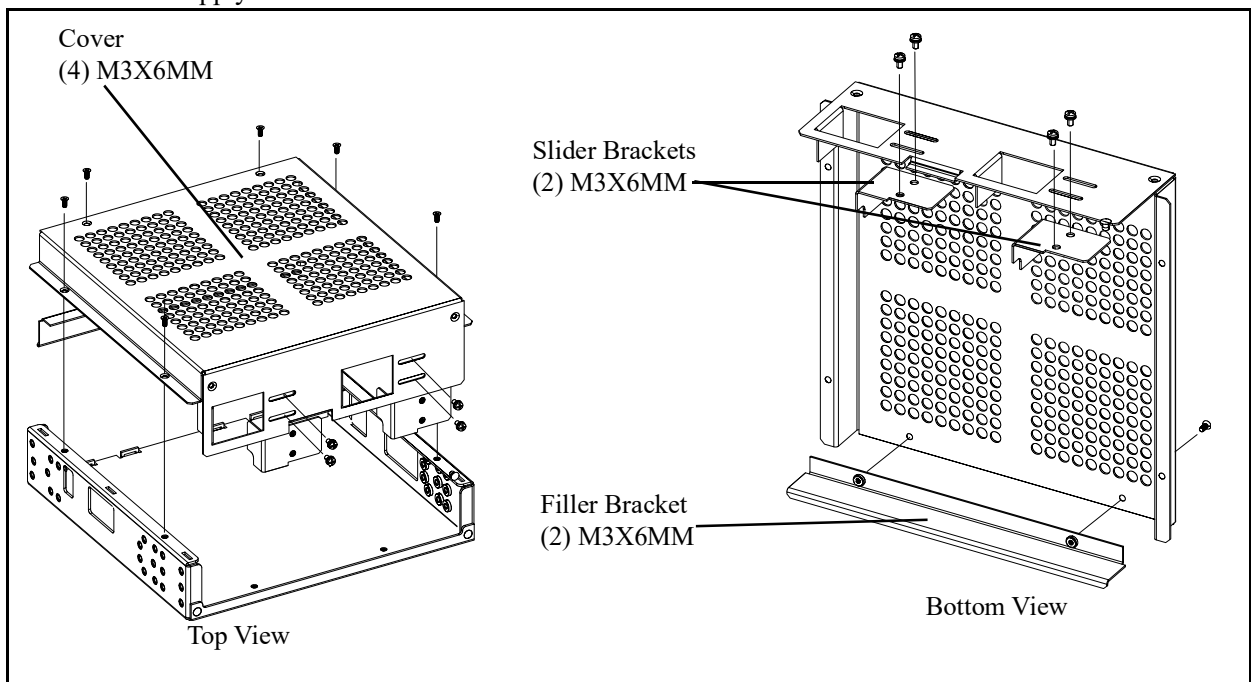

Power Supply Tray Cover (Power Supplies Not Shown)

4 Final Assembly

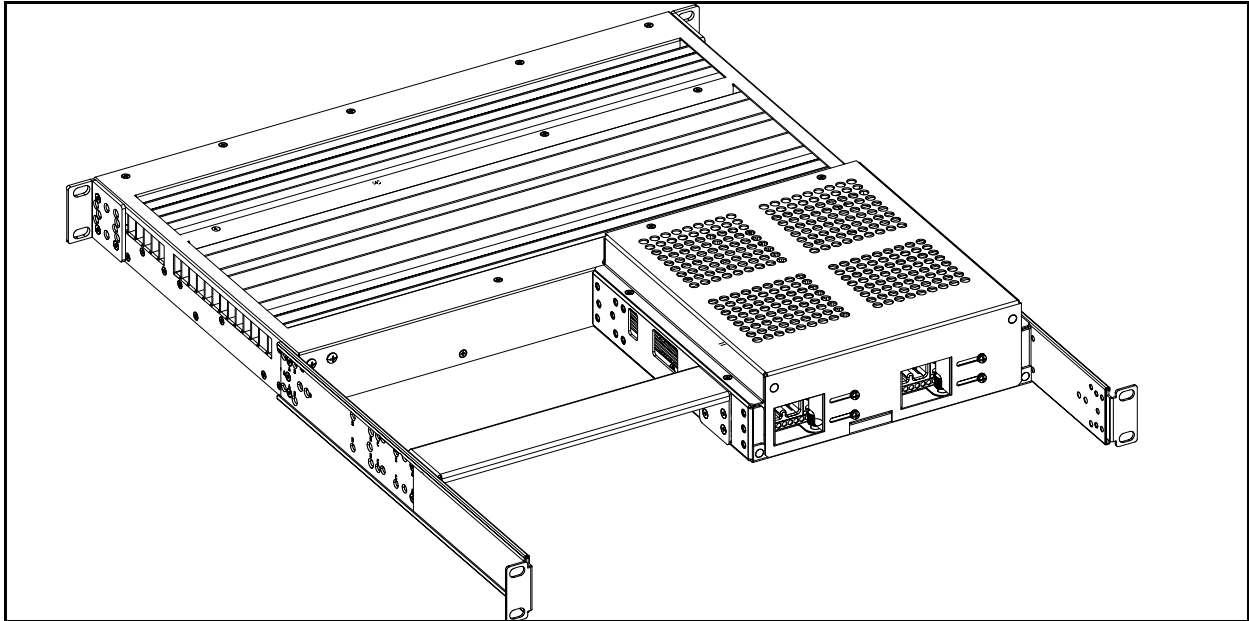

Final Assembly

Power Supplies

OmniSwitch 6465 switches can use the following power supplies:

Model	Chassis Supported
OS6465-BPN-X(See page 3-31)	OS6465-P12 (ENH-240)
OS6465-BPN-H(See page 3-32)	OS6465-P6, OS6465-P12, OS6465-P12 (ENH-240)
OS6465-BPN (See page 3-33)	OS6465-P6, OS6465-P12, OS6465-P12 (ENH-240)
OS6465-BPR (See page 3-34)	OS6465-P28
OS6465-BPRD (See page 3-35)	OS6465-P28
Internal Power Supplies (See page 3-36)	OS6465T-12, OS6465T-P12

The power supplies connectors are located at the front of the switch chassis. Refer to “[OmniSwitch 6465 Chassis Details](#)” for more information on component locations. Two connectors are provided. If a second power supply is connected only the OmniSwitch 6465-P28 supports power supply load sharing for Power over Ethernet, other models support power supply redundancy only. See “[Managing Power over Ethernet \(PoE\)](#)”.

Please note that the chassis does not provide an on/off switch. Connecting a power supply to a power source will boot the switch. Likewise, disconnecting all installed power supplies from a power source will power off the switch.

OS6465-BPN-X AC Power Supply

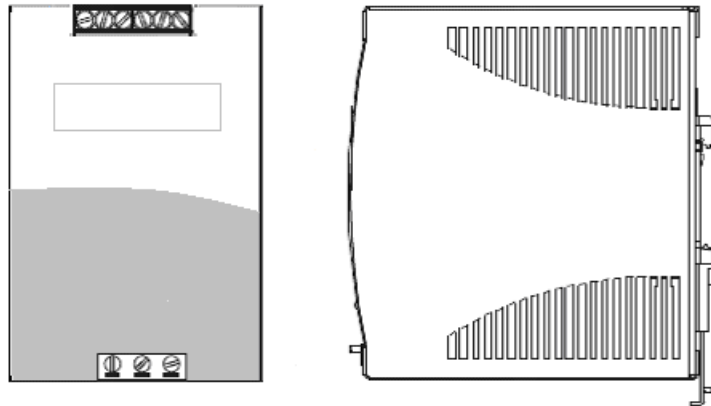

480W AC Power Supply

Model	OS6465-BPN-X (PS-I275AC-P , SDR-480-48)
Models Supported	OS6465-P12 (ENH-240)
Input Voltage Range	100 - 240VAC
Input Frequency	50/60Hz
Input Current	5.0A
Output Voltage	48VDC
Output Current	10A
Output Power	480W
Max. Output for PoE Power	See “Power over Ethernet Budget” .

Note: This power supply has not been submitted for validation to meet the industrial certification requirements.

LED States

LED State	Description
DC OK LED Solid Green	DC power is good
DC OK LED Solid Red	There is a DC power issue

OS6465-BPN-H AC Power Supply

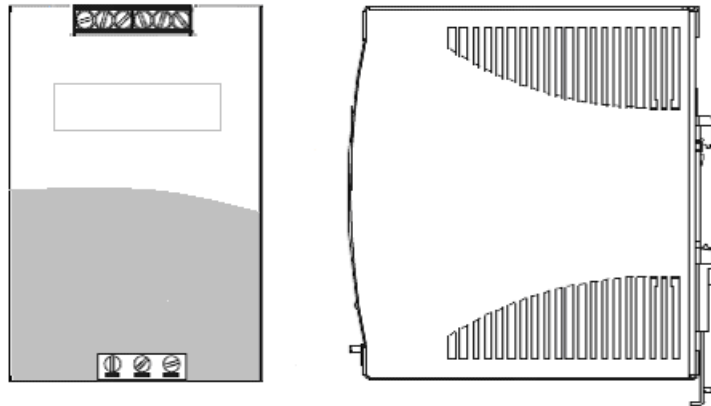

180W AC Power Supply

Model	OS6465-BPN-H (PS-I185AC-P, SDR-240-55)
Models Supported	OS6465-P6, OS6465-P12, OS6465-P12 (ENH-240)
Input Voltage Range	100 - 240VAC
Input Frequency	50/60Hz
Input Current	2.6A
Output Voltage	54.5VDC
Output Current	3.5A
Output Power	180W
Max. Output for PoE Power	See “Power over Ethernet Budget” .

LED States

LED State	Description
DC OK LED Solid Green	DC power is good
DC OK LED Solid Red	There is a DC power issue

OS6465-BPN AC Power Supply

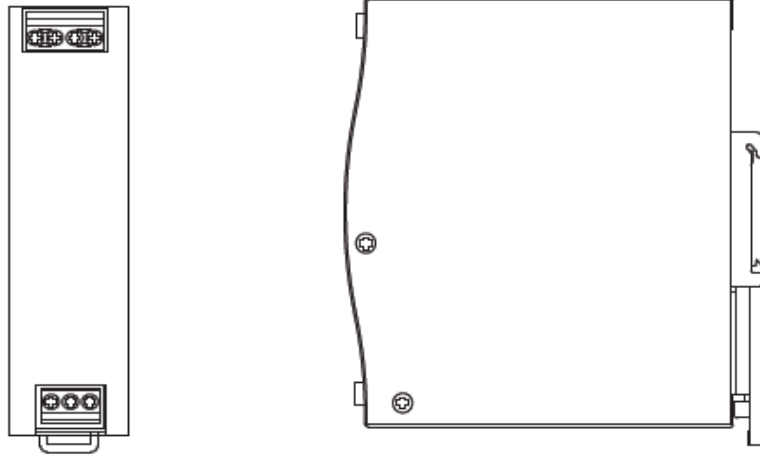

75W AC Power Supply

Model	OS6465-BPN (PS-I75AC, SDR-75-48)
Models Supported	OS6465-P6, OS6465-P12, OS6465-P12 (ENH-240)
Input Voltage Range	100 - 240VAC
Input Frequency	47 - 63Hz
Input Current	1.5A
Output Voltage	-48VDC
Output Current	1.6A
Output Power	75W
Max. Output for PoE Power	See “Power over Ethernet Budget” .

LED States

LED State	Description
DC OK LED Solid Green	DC power is good
DC OK LED Solid Red	There is a DC power issue

OS6465-BPR Power Supply

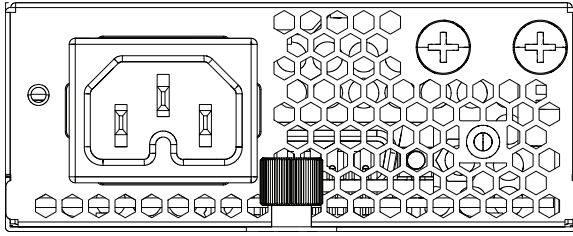

Power Supply Front

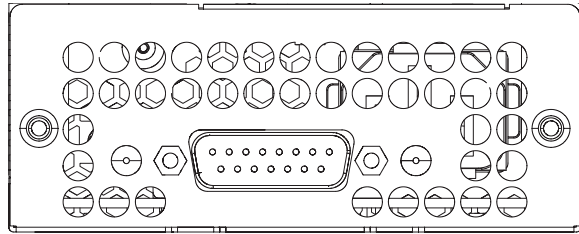

Power Supply Rear

Model	OS6465-BPR (PS-I180AC-P)
Description	Modular AC power supply. Up to two (2) power supplies may be installed.
Dimensions (H x W x L)	5.1 cm x 9.5 cm x 18.1 cm (2 in x 3.74 in x 7.12 in)
Weight	1.36 kg (3.00 lbs)
Models Supported	OS6465-P28
Input Voltage / Current / Hz	100 VAC to 240 VAC / 3 A - 1.5 A / 50-60 Hz
Output Voltage / Current	+56 VDC / 3.22 A
Status LEDs	Solid Green indicates normal operation
Max. Output for PoE Power	See “Power over Ethernet Budget” .

OS6465-BPRD 180W DC Power Supply

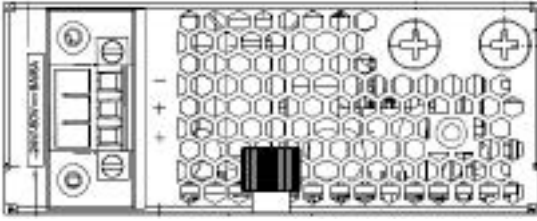

Power Supply Front

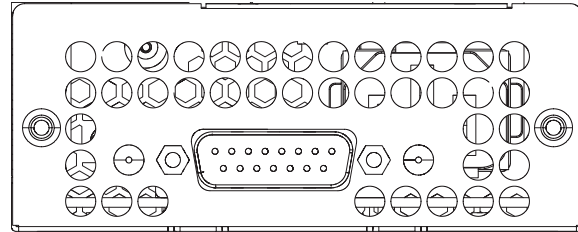

Power Supply Rear

Model	OS6465-BPRD (PS-I180DC-P)
Description	Modular DC power supply. Up to two (2) power supplies may be installed.
Dimensions (H x W x L)	5.1 cm x 9.5 cm x 18.1 cm (2 in x 3.74 in x 7.12 in)
Weight	1.44 kg (3.17 lbs)
Models Supported	OS6465-P28
Input Voltage / Current	-20 VDC to -28 VDC / 12A -36 VDC to -72 VDC / 6A
Output Voltage / Current	-56V/2.5A (140W) -56V/3.22A (180W)
Status LEDs	Solid Green indicates normal operation
Max. Output for PoE Power	See “Power over Ethernet Budget” .

Internal Power Supplies

Model	65W Internal Power Supply
Description	Internal 65W power supply
Models Supported	OS6465T-12
Input	100-240V, 50-60Hz, 1.5A
Output	12V/5.42A (65W)

Model	185W Internal Power Supply
Description	Internal 185W power supply
Models Supported	OS6465T-P12
Input	100-240V, 50-60Hz, 2.5A
Output	12V/5.42A, +54.5V/2.2A (185W)
Max. Output for PoE Power	See “Power over Ethernet Budget” .

Installing Power Supplies for Rear Mount Trays

1. Orient the power supply as shown below. Insert the guide pins (located on either side of the DB-15 connector) into the guide holes in the rear of the chassis.

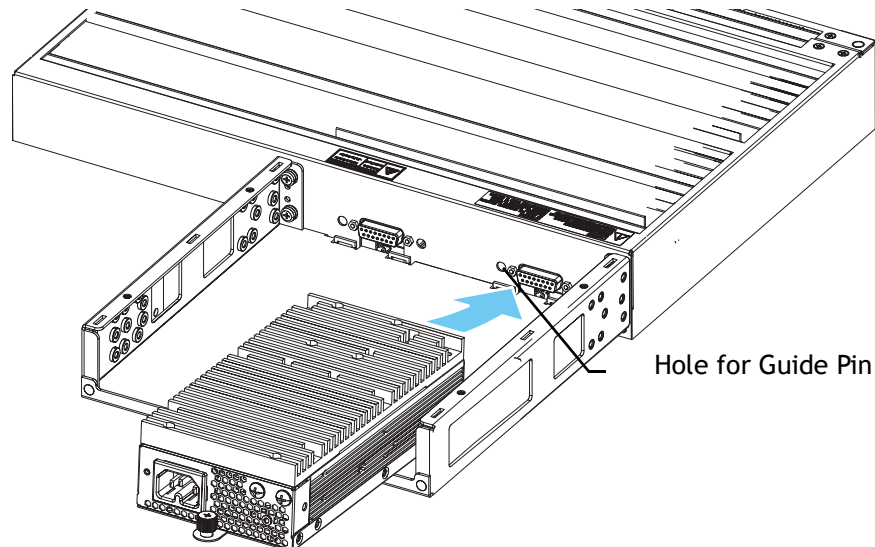

Align power supply guide pins and slide into position

2. Push the power supply into place until the connector is fully seated and tighten the thumb screw at the front of the power supply unit.

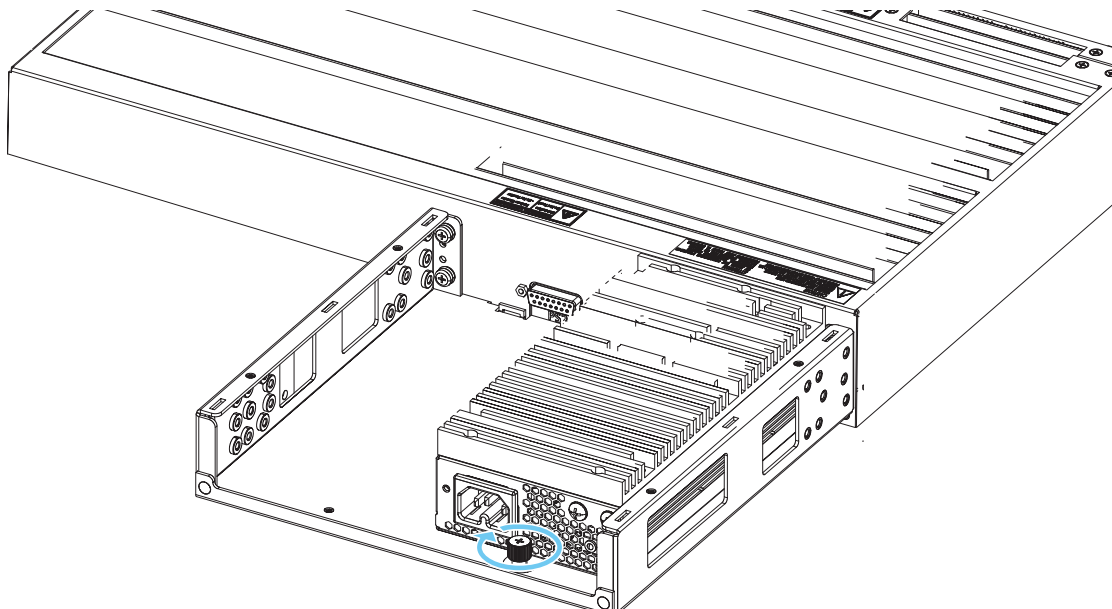

Secure power supply with thumb screw

3. For redundant power supply configurations, repeat these steps using the power supply connector and thumb screw hole located at the other side of the chassis and power supply tray.

Connecting the AC Power Supplies

Connecting the Removed Outer Jacket (ROJ) Power Cords

AC Input Wire Color and Cord Type

Power Supply Label	North America Wire Color	International Wire Color
L (Line)	Black (30mm ROJ)	Brown (30mm ROJ)
N (Neutral)	White (30mm ROJ)	Blue (30mm ROJ)
Protective Ground (PG)	Green (33mm ROJ)	Green/Yellow Stripe (33mm ROJ)

DC Output Wire Color

Power Supply Label	North America and International (Use same power cord)
V-	Red (ROJ)
V+	Black (ROJ)
Protective Ground (PG)	Green (ROJ with grounding lug)

Parts Required

Only parts provided by Alcatel-Lucent Enterprise should be used when installing the power supplies.

The PoE power supply uses both an input and output power cord with Removed Outer Jackets (ROJ):

- An AC power cord that provides input power from an AC power source to the power supply.
- An output power cord that provides output power from the power supply to the chassis.

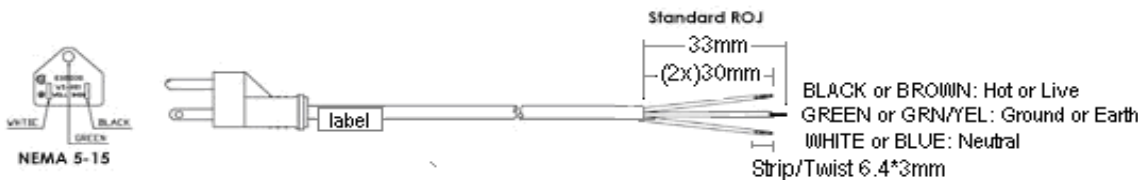

AC ROJ Input Power Cord



DC ROJ Output Power Cord

Warning. Do not insert the NEMA 5-15 plug or power connector into the power supply or any live power source until prompted to do so. Failure to follow these instructions may result in bodily injury and/or equipment damage.

Be sure to properly install the power cords by following the steps below.

- 1** To install the output power cord, begin by inserting the RED wire into either of the V- terminals located at the top-front of the power supply and the negative terminal (-) on the switch power supply connector.
- 2** Next, insert the BLACK wire into either of the V+ terminals on the power supply and the positive (+) terminal on the switch power supply connector.
- 3** Using a screwdriver torque each terminal to approximately 3.5 inch-pounds.
- 4** Secure the remaining ground wire to the power supply using the supplied attachment screw. Insert the screw through the ground wire connector and tighten firmly. Connect other end to ground terminal on switch power connector.

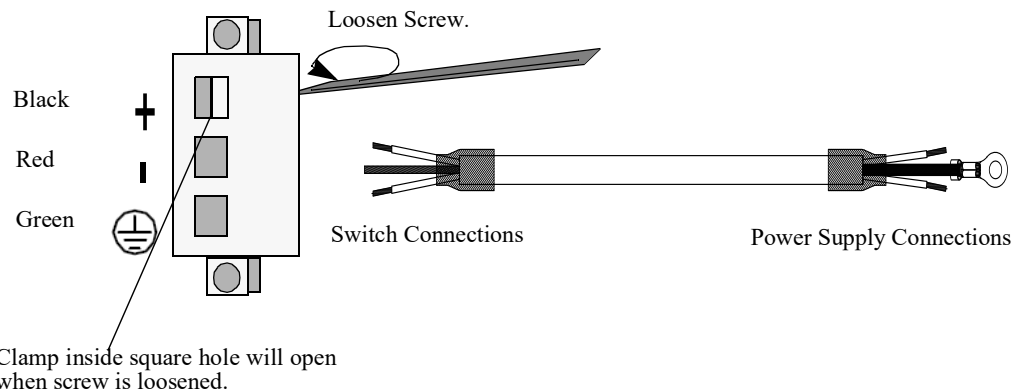
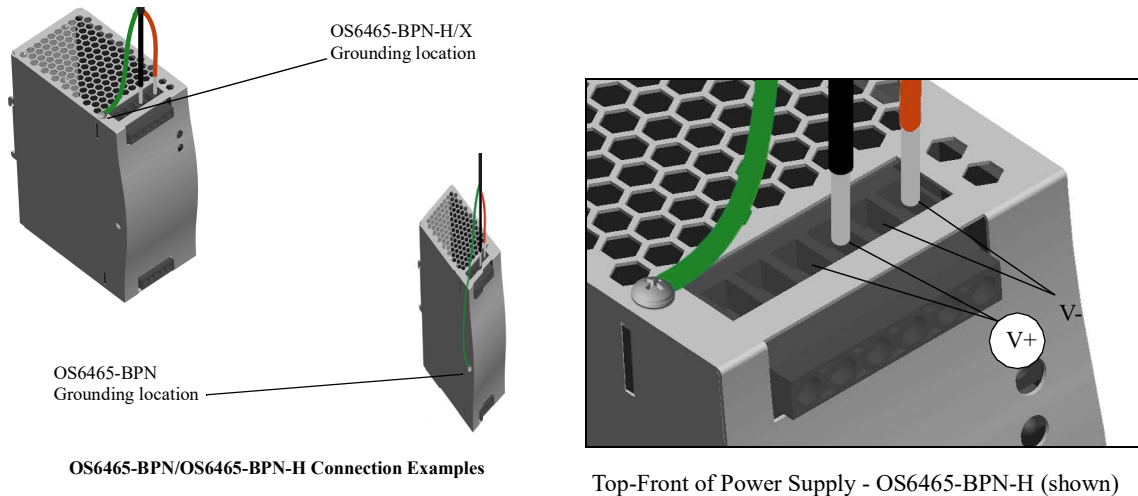

Output Power Terminal Locations

- 5 To connect the AC power cord, begin by inserting the BLACK (North America) or BROWN (International) wire into the Line (L) terminal located at the bottom-front of the power supply.
- 6 Next, insert the WHITE (North America) or BLUE (International) wire into the Neutral (N) terminal.
- 7 Insert the GREEN (North America) or GREEN/YELLOW stripe (International) ground wire into the terminal marked with the protective ground symbol.

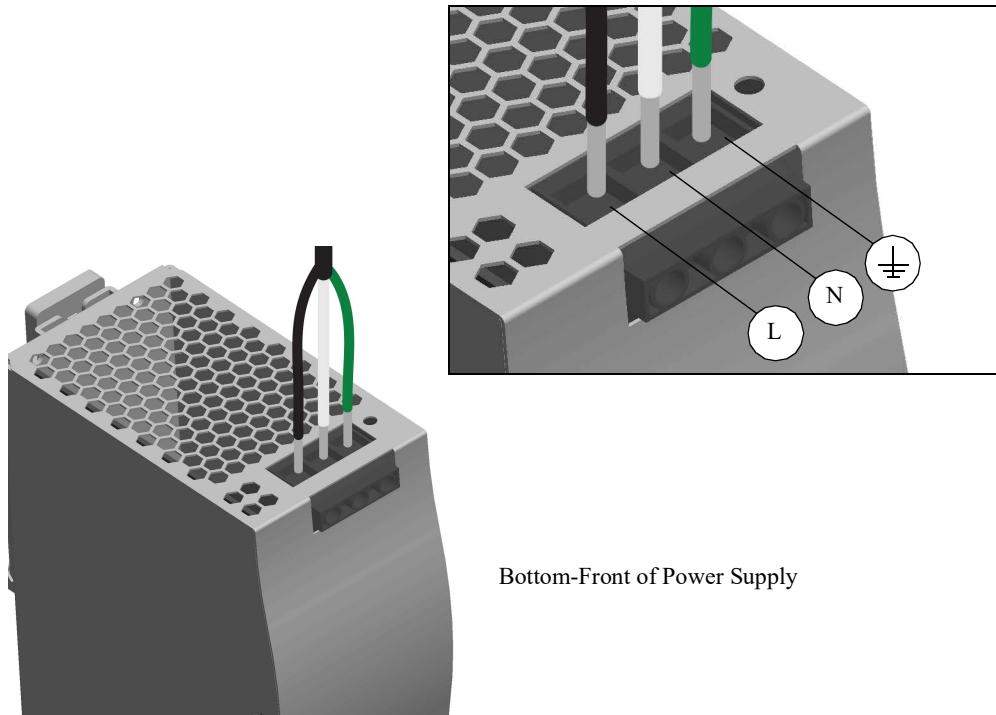

Bottom-Front of Power Supply

Input Power Terminal Locations (North America wire color shown)

- 8 Using a screwdriver torque each terminal to the inch-pounds labeled on the power supply.

Final Power Cord Connections

- 1 Insert the output power cord into the power connector (PS1 or PS2) located on the front of chassis (if required).
- 2 Plug the AC power cord's NEMA 5-15 into an easily accessible AC power source.

Caution. The product uses a Pluggable Type A power cord; therefore, please make sure that the power socket is located near the equipment and is easily accessible.

Configuring a Power Supply

The OmniSwitch 6465 cannot auto-detect the type of power supply connected. The type of power supply connected must be configured so that the system and PoE power information is correctly displayed and utilized. Use the `powersupply type` command to configure the power supply, for example:

```
-> powersupply 1 name ALE-75W-ps1 type ale lo-ac  
-> powersupply 2 name ALE-75W-ps2 type ale lo-ac
```

Hot-Swapping / Removing a Power Supply

Follow the steps below to remove a power supply. Please note that if the chassis is running with redundant power supplies, either one of the power supplies can be replaced without affecting chassis operation (hot-swap).

- 1** Unplug the power supply from the power source.
- 2** Disconnect the AC input power cord from the power supply by loosening all terminal connectors and disconnecting the wires from the power supply.
- 3** Disconnect the output power cord from the power supply by loosening all terminal connectors and disconnecting the wires from the power supply.
- 4** Reconnect the new power supply by following the steps provided in [“Connecting the AC Power Supplies”](#)

Grounding the Chassis

The switch has a grounding lug located on the front or rear of the chassis. This lug uses 10-32 screws and is surrounded by a small paint-free area, which provides metal-to-metal contact for a ground connection.

Use this connector to supplement the ground provided by the AC power cord. To do so, install a Panduit Grounding Lug (type LCD8-10A-L) using 8AWG copper conductors to the paint-free area.

Refer to the chassis views on [page 3-2](#) for location details.

Alarm Relay

The alarm relay feature is used for notification whenever there is a system event on the switch or an alarm input. Notification is either by an alarm output, trap or by logging a SWLog message.

There is a single line alarm input to the switch which can be connected to an external source. External sources can be temperature, proximity, door open sensors as examples. The alarm input status is also indicated to the user by the alarm input LED.

There is a single line alarm output from the switch. The alarm output is user configurable for associating any system event or an alarm input. Alarm output status is also indicated to the user by the alarm output LED.

Alarm relay is supported on both standalone and virtual chassis (VC).

On standalone system: The alarm input, traps, and system events are mapped to the local chassis alarm output.

On VC: The alarm input, traps, and system events are synced across all the chassis of the VC. The alarm output on any of the chassis can be set by the alarm input, trap, or system events of any other chassis.

- User can connect different external devices (sensors) to alarm inputs of different chassis.
- User can map the single alarm input or event to multiple chassis alarm outputs for redundancy.
- User can map multiple inputs or events to single alarm output on any chassis.

The alarm status is indicated to the user by the alarm LEDs as noted below:

Events	Input LED	Output LED
Alarm input with action alarm output	On	On
Alarm input with action trap	On	Off
Alarm input with action SWLog	On	Off
Alarm output due to system events	Off	On

Use the [alarm](#) command to configure the alarm relay feature.

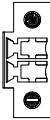
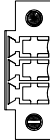
Alarm	Specifications	Connector
Alarm Relay Input 	Input range: 5VDC 5- 12VDC	1 - Positive 2 - Ground
Alarm Relay Output 	- Max Switching Voltage - 220VDC, 250VAC - Max Switching / Carrying Current - 2 A - Max Power - 60W	1 - Normally Open (NO) 2 - Common (C) 3 - Normally Closed (NC)

Alarm Relay Configuration Examples

The following shows an example of configuring an alarm-out action based on the alarm relay input being activated. The alarm-out action will trigger the alarm relay output.

```
-> alarm in temperature-alarm-in action alarm-out-1 admin-state enable
-> alarm out alarm-out-1 admin-state enable
-> alarm map temperature-alarm-in out alarm-out-1
```

The following shows an example of how to map an 'authentication-failure' event to trigger the alarm output relay.

```
-> alarm event auth-fail-event event authentication-failure admin-state enable
-> alarm out set-alarm-out-chassis-1
-> alarm map auth-fail-event out set-alarm-out-chassis-1
-> show alarm event config
Alarm Duration 24 hrs 0 Mins
Alarm-Name      Chassis-in  Network-Port  Trap-Id  Event-Name  Admin-State  Alarm-Output-Name  Chassis-out
-----+-----+-----+-----+-----+-----+-----+-----
auth-fail-event 1          -            -        authentication-failure  enable  set-alarm-out-chassis-1  1
```

If there is an authentication failure detected on Chassis 1, the alarm output relay will be triggered, the LED for the alarm output relay will be turned on and the alarm will be logged as seen below.

```
-> show alarm status
Alarm-Name      Chassis-in  Time-Stamp    Network-Port  Trap-Id  Event-Name  Alarm-Output-Name  Chassis-out
-----+-----+-----+-----+-----+-----+-----+-----
auth-fail-event 1          03/01/14 : 01:18:51  - -        authentication-failure  set-alarm-out-chassis-1  1
```

To clear the alarm the **alarm clear status** command can be used.

```
-> alarm clear status
```

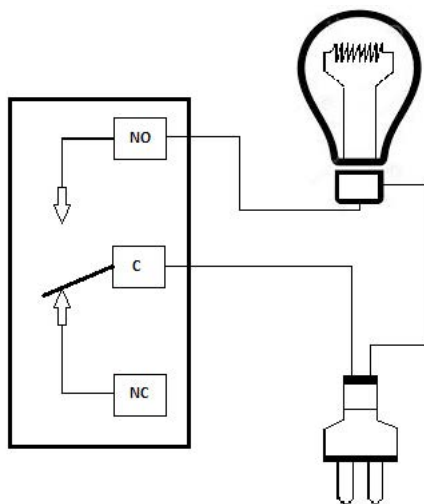

When the alarm relay output is triggered, the **normally open (NO)** contact will close and the **normally closed (NC)** contact will open.

Alarm Relay Output Wiring Diagram Example

Monitoring Chassis Components

Viewing Chassis Slot Information

To view basic slot information, enter the show module command at the CLI prompt:

```
-> show module
```

To view more detailed information, use the show module long command:

```
-> show module long
```

Monitoring Chassis Temperature

The operating temperature of your switch is a critical factor in its overall operability. In order to avoid a temperature-related system failure, your switch must always run at a temperature within the specified operating temperature range.

To avoid chassis over-temperature conditions, follow the important chassis airflow recommendations on [page 3-18](#).

To check the switch's current temperature status, use the **show temperature** command. For example:

```
-> show temperature
Chassis/Device | Current | Range      | Danger | Thresh | Status
-----+-----+-----+-----+-----+-----
1/CMMA         | 33      | -45 to 93  | 98     | 93     | UNDER THRESHOLD
```

For more information about this command, see the “Chassis Management and Monitoring Commands” chapter in the *OmniSwitch CLI Reference Guide*.

Temperature Errors

The switch monitors the chassis temperature at all times via an onboard sensor. If an over-temperature condition occurs, there are two different levels of error severity:

- Warning threshold (*Thresh*) temperature has been exceeded
- Danger threshold has been exceeded

Warning Threshold Temperature

If the temperature exceeds the switch's Warning threshold, the switch sends out a trap. Traps are also printed to the console in the form of text error messages.

When the Warning threshold has been exceeded, switch operations remain active. However, it is recommended that immediate steps be taken to address the over-temperature condition.

Addressing Warning threshold conditions may include:

- Checking for a chassis airflow obstruction
- Checking the ambient room temperature

Danger Threshold

If the chassis temperature rises above the Danger threshold, the switch will power off until the temperature conditions have been addressed and the switch is manually booted. The Danger threshold is factory-set and cannot be configured by the user.

Addressing the Danger threshold conditions may include:

- Checking for a chassis airflow obstruction
- Checking the ambient room temperature

Dying Gasp

If the switch loses all power it will maintain power long enough to send a Dying Gasp message before completely shutting down. An SNMP trap, Syslog message and Link OAM PDUs will be generated.

Scenarios

A Dying Gasp event will be generated in the following scenarios:

- Primary power supply failure (if only power supply present)
- Primary power supply failure and then backup power supply failure
- Backup power supply failure and then primary power supply failure

Note. Connect each power supply to a separate independent power source to avoid simultaneous power failures.

SNMP Trap

As soon as the power failure is detected, an SNMP trap is sent to the first three configured SNMP stations. The trap includes the following information:

- Slot number
- Power supply type (primary/backup)
- Time of the failure

Use the `snmp station` command and refer to the SNMP Configuration chapter for information on configuring an SNMP station.

Syslog Message

As soon as the power failure is detected, the following Syslog message is sent to the first three configured Syslog servers, along with the time of the failure:

```
Dying Gasp Power Failure Event Occurred
```

Use the `swlog output socket` command to add a Syslog station. Refer to the *Using Switch Logging Configuration* chapter in the *Network Configuration Guide* for information on configuring a Syslog server.

Link OAM PDU

As soon as the power failure is detected four 802.3ah OAM Information PDUs are sent to ports for which link OAM is enabled and the LinkOAM port status is operational. The PDU will have the Dying Gasp bit set.

Use the `efm-oam` and `efm-oam port propagate-events` commands to enable the generation of an 802.3ah OAM Information PDU upon a dying gasp event:

```
-> efm-oam admin-state enable
-> efm-oam port 1/1/23-34 admin-state enable
-> efm-oam port 1/1/23-24 propagate-events dying-gasp enable
```

Link OAM PDU Priority

It may not be possible to generate PDUs on all ports enabled for link OAM. Dying gasp packets will be sent in the following order based on port priority:

1. Uplink ports
2. All other ports

4 Managing Power over Ethernet (PoE)

Power over Ethernet (PoE) provides inline power directly from the switch's Ethernet ports. Powered Devices (PDs) such as IP phones, wireless LAN stations, Ethernet hubs, and other access points can be plugged directly into the Ethernet. From these RJ-45 the devices receive both electrical power and data flow.

As the feature reduces devices' dependence on conventional power sources, PoE eliminates many restrictions that traditional electrical considerations have imposed on networks.

In a PoE configuration, Power Source Equipment (PSE) detects the presence of a PD and provides an electrical current that is conducted along the data cable. The PD operates using the power received via the Ethernet data cable; no connection to an additional power source (e.g., an AC wall socket) is required.

Note on Terminology. There are several general terms used to describe the feature, PoE. The terms *Power over Ethernet (PoE)*, *Power over LAN (PoL)*, *Power on LAN (PoL)*, and *Inline Power* are synonymous terms used to describe the powering of attached devices via Ethernet. For consistency, this chapter and the *CLI Command Reference Guide* refer to the feature as *Power over Ethernet (PoE)*.

Additional terms, such as *Powered Device (PD)* and *Power Source Equipment (PSE)* are not synonymous with PoE, but are directly related to the feature:

- *PD* refers to any attached device that uses a PoE data cable as its only source of power. Examples include access points, IP telephones, Ethernet hubs, wireless LAN stations, etc.
- *PSE* refers to power sourcing equipment, which provides power to a single link section. PSE main functions include searching the PD, optionally classifying the PD, supplying power to the link section only if the PD is detected, monitoring the power on the link section, and scaling power back to detect level when power is no longer requested or required.

As the switches fully support Ethernet connectivity, you may also attach non-PD equipment, such as computer workstations, printers, servers, etc. to the PoE ports.

Important. It's recommended that PoE-enabled switches with attached IP telephones should have operational power supply redundancy at all times for 911 emergency requirements. In addition, both the switch and the power supply should be plugged into an Uninterruptible Power Source (UPS).

In This Chapter

This chapter provides specifications and descriptions of hardware and software used to provide PoE for attached devices.

The chapter also provides information on configuring PoE settings on the switch through the Command Line Interface (CLI). CLI commands are used in the configuration examples; for more details about the syntax of commands, see the *OmniSwitch CLI Reference Guide*. Topics and configuration procedures described in this chapter include:

- Power over Ethernet Specifications on [page 4-3](#)
- Viewing Power Status on [page 4-4](#)
- Configuring Power over Ethernet Parameters on [page 4-4](#)
- Understanding Priority Disconnect on [page 4-11](#)
- Monitoring Power over Ethernet via the CLI on [page 4-14](#)

Note. Before PoE functionality can be configured the type of power supply connected must be configured. See “[Configuring a Power Supply](#)” for additional information.

Power over Ethernet Specifications

The table below lists general specifications for Alcatel-Lucent's Power over Ethernet support. For more detailed power supply and Power Source Equipment (PSE) specifications, refer to [Chapter 3, "Chassis and Power Supplies."](#)

IEEE Standards supported	IEEE 802.3at
PoE Class Detection	Supported
Platforms supporting PoE	All
Range of inline power per port	802.3at ports - 3000-30000 milliwatts 802.3at ports (HPoE) - 3000-60000 milliwatts
Maximum PoE power per slot	See "Power over Ethernet Budget" .

Power over Ethernet Defaults

The following table lists the defaults for PoE configuration:

Parameter Description	Command(s)	Default Value/Comments
PoE operational status	lanpower slot service	Disabled
Power available to a port	lanpower power	802.3at ports - 30000 milliwatts 802.3at ports (HPoE) - 60000 milliwatts
Power available to an entire slot	lanpower slot maxpower	See "Power over Ethernet Budget" .
Power priority level for a port	lanpower priority	low
Capacitor detection method	lanpower capacitor-detection	Disabled
Priority disconnect status	lanpower slot priority-disconnect	Enabled

Power over Ethernet Budget

The following table lists the Power over Ethernet wattages available based on the number and types of power supplies installed and the ambient temperature.

Ambient Temperature	OmniSwitch	One (1) or Two (2) PS-I75AC	One (1) or Two (2) PS-I185AC-P	One (1) or Two (2) PS-I275AC-P	Internal P/S
60°C or lower	OS6465T-P12	N/A	N/A	N/A	115W
60°C or lower	OS6465-P6 OS6465-P12	45W	150W	N/A	N/A
	OS6465-P12 (ENH-240)	45W	150W	240W	N/A
Between 60°C to 70°C (100 CFM air-flow)	OS6465-P6 OS6465-P12	30W	130W	N/A	N/A
	OS6465-P12 (ENH-240)	30W	130W	240W	N/A
Between 70°C to 75°C	OS6465-P6 OS6465-P12 OS6465-P12 (ENH-240)	No PoE Provided	No PoE Provided	No PoE Provided	N/A

OmniSwitch 6465-P6/P12/P12 (ENH-240) and 6465T-P12 PoE Budget

Ambient Temperature	OmniSwitch	One (1) PS-I180AC-P or PS-I180DC-P
Up to 75°C	OS6465-P28	112W (PS-I180AC-P) 112W (PS-I180DC-P @ 48VDC) 72W (PS-I180DC-P @ 24VDC)
		Two (2) PS-I180AC-P or PS-I180DC-P 285W (2 x PS-I180AC-P or 2 x PS-I180DC-P @ 48VDC) 205W (2 x PS-I180DC-P @ 24VDC) 205W (1 x PS-I180DC-P @ 24VDC and 1 x PS-I180AC-P) 205W (1 x PS-I180DC-P @ 24VDC and 1 x PS-I180DC-P @ 48VDC)

OmniSwitch 6465-P28 PoE Budget

Viewing Power Supply Status

To view the type and status for installed power supplies, use the `show powersupply` command:

```
-> show powersupply
Total      PS
Chassis/PS  Power    Type    Status  Location
-----+-----+-----+-----+-----
1/1         75       AC      UNPLUG  Internal
Total      75
```

Viewing PoE Status

To view current PoE status and settings, use the **show lanpower slot** command:

Port	Maximum(mW)	Actual Used(mW)	Status	Priority	On/Off	Class	Type
1	60000	0	Powered Off	Low	OFF	.	.
2	30000	0	Powered Off	Low	OFF	.	.
3	60000	0	Powered Off	Low	OFF	.	.
4	30000	0	Powered Off	Low	OFF	.	.

```
ChassisId 1 Slot 1 Max Watts 45
0 Watts Actual Power Consumed
0 Watts Total Power Budget Used
45 Watts Total Power Budget Available
1 Power Supply Available
'*' appending port maxpower indicates 4pair port operating in 2pair mode
```

Understanding and Modifying the Default Settings

The sections below provide information on each of the key components within the Power over Ethernet software. They include information on PoE-related CLI commands. For detailed information on PoE-related commands, refer to the *OmniSwitch CLI Reference Guide*.

PoE Class Detection

Powered devices can be classified into different classes as shown in the table below. Class detection allows for automatic maximum power adjustment based on the power class detected. This will prevent the switch from delivering more than the maximum power allowed based on a device's class.

During class detection, the switch will allocate the maximum amount of power allowed based on the class detected. Once powered, if the device uses less than the maximum, the remaining power will be made available for other devices.

Standard	Class	Type	Pairs	Power at Port (Watts)
IEEE 802.3af	0	1	2	15.4
	1	1	2	4.0
	2	1	2	7.0
	3	1	2	15.4
802.3at	4	2	2	30
802.3bt	5	3	4	45
	6	3	4	60
	7	4	4	75
	8	4	4	90-99

Although class-detection is disabled by default, the switch still provides power to incoming PDs (if available in the power budget). However, to strictly enforce class detection as specified in the 802.3at standard, class detection must be enabled using the **lanpower slot class-detection** command.

Enabling class detection will reset all PoE ports on the chassis.

PoE Operational Status

Enabling PoE

By default, Power over Ethernet is *administratively enabled* in the switch's system software. However, in order to physically activate PoE, you must issue the **lanpower slot service** command on a slot-by-slot basis before any connected PDs will receive inline power.

To activate power to PoE-capable in a switch, enter the corresponding slot number only. For example:

```
-> lanpower slot 1/1 service start
```

If power to a particular port has been administratively disconnected, you can reactivate power to the port using the **lanpower port admin-state** command. For example:

```
-> lanpower port 1/1/1-4 admin-state enable
```

Note. You cannot use the **lanpower port admin-state** command to initially activate PoE on a port. This syntax is intended only to reactivate power to those that have been disconnected via the **lanpower slot service** command. To initially activate PoE, you must use the **lanpower slot service** command as described above.

Disabling PoE

To disable PoE on a particular port, use the **lanpower port admin-state** command. For example:

```
-> lanpower port 1/1/4 admin-state disable
```

To disable PoE for *all PoE-capable ports in a slot*, use the **lanpower slot service** command. For example:

```
-> lanpower slot 1/1 service stop
```

Configuring the Total Power Available to a Port

By default, each port is authorized by the system software to use up to a maximum amount of milliwatts to power any attached device.

You can either increase or decrease this value based on the allowed ranges.

Increasing the total power available to an individual port may provide a more demanding Powered Device (PD) with additional power required for operation. Decreasing the total power available to a port helps to preserve inline power and assists in the overall management of the switch's power budget.

To increase or decrease the total power available to an individual port, use the **lanpower power** command. Since you are setting the power allowance for an individual port, you must specify *chassis/slot/port* values in the command line. For example, the syntax

```
-> lanpower port 1/1/4 power 3000
```

reduces the power allowance on the port to 3000 milliwatts. This new value is now the maximum amount of power the port can use to power any attached device (until the value is modified by the user).

Configuring the Total Power Available to a slot

Like the maximum port power allowance, the system software also provides a maximum *slot-wide* power allowance. By default, each slot is authorized by the system software to use a number of watts to power all devices connected to its ports depending on which power supply is used.

As with the maximum port power allowance, the user can either increase or decrease this value based on the allowed ranges.

Important. Decreasing the slot-wide power could cause lower priority ports to lose power if the new value is less than the total PoE power currently being consumed.

To increase or decrease the total power available to a slot, use the **lanpower slot maxpower** command. Since you are setting the power allowance for an individual slot, you must specify a *chassis/slot* value in the command line. For example, the syntax

```
-> lanpower slot 1/1 maxpower 400
```

reduces the power allowance of the slot to 400 watts. This value is now the maximum amount of power the slot can use to power all attached devices (until the value is modified by the user).

Note. Changing the maximum power available to a slot or port **does not** reserve or immediately allocate that power. These settings are only used for configuring a maximum amount of power that may be used, any unused power is still available and remains a part of the overall PoE budget.

Setting Port Priority Levels

As not all Powered Devices (PDs) connected to the switch have the same priority within a network setting, the OmniSwitch allows the administrator to specify priority levels on a port-by-port basis. Priority levels include low, high, and critical. The default priority level for a port is low.

- **Low.** This default value is used for port(s) that have low-priority devices attached. In the event of a power management issue, inline power to low-priority is interrupted first (i.e., before critical and high-priority).
- **High.** This value is used for port(s) that have important, but *not* mission-critical, devices attached. If other ports in the chassis have been configured as critical, inline power to high-priority is given second priority.
- **Critical.** This value is used for port(s) that have mission-critical devices attached, and therefore require top (i.e., critical) priority. In the event of a power management issue, inline power to critical is maintained as long as possible.

To change the priority level for a particular port, use the **lanpower priority** command. Since the switch allows you to set priority levels on a port-by-port basis, be sure to specify *chassis/slot/port* information in the command line. For example, the syntax

```
-> lanpower port 1/1/4 priority critical
```

changes the priority value of the port to the highest priority level of critical. Now that the default value has been reconfigured, this port should be reserved for those PDs that are mission critical for network operations.

Setting the Capacitor Detection Method

By default, the capacitor detection method is disabled. To enable it, use the [lanpower capacitor-detection](#). For example:

```
-> lanpower slot 3/1 capacitor-detection enable
```

Note. The capacitive detection method should only be enabled to support legacy IP phones. This feature is *not* compatible with IEEE specifications. Please contact your Alcatel-Lucent sales engineer or Customer Support representative to find out which Alcatel-Lucent IP phones models need capacitive detection enabled.

Understanding Guard Band

Guard Band functionality is implemented when the switch has to provide power to a newly connected PD. This functionality is more relevant on switches that have a lower amount of total PoE power available for the switch but a higher default maximum PoE power available to some ports.

- If the amount of power remaining is less than the port's configured maximum PoE power value or the PD's class maximum power then the switch will not power up the PD.
- This applies even if the newly connected PD actually requires less than the maximum power available for the port.

For example, assume the following:

- There is 50W of PoE power remaining on the switch.
- A newly connected PD only requires 4W of power.
- The port's maximum PoE power value is 75W.

In this example the newly connected PD will not be powered on since the port's maximum PoE power value is greater than the PoE power remaining on the switch.

To allow the PD to be powered, the port's maximum PoE value can be configured to be less than the power remaining by issuing the following command to set the port's maximum PoE power to 10W:

```
-> lanpower power 1/1/1 power 10000
```

Using the previous example:

- There is 50W of PoE power remaining on the switch.
- A newly connected PD only requires 4W of power.
- The port's maximum PoE power value is now 10W.

The newly connected PD will be powered on since the port's maximum PoE power value is now less than the PoE power remaining on the switch. The examples assume the new PD has the same or lower priority as the existing PDs, otherwise priority disconnect will override.

The Guard Band functionality does not apply to PDs that are already powered up. However, priority disconnect will apply if there's not enough power to power all PDs in the case of the power budget being reduced, such as the removal of a power supply.

Please refer to the [“Understanding Priority Disconnect” on page 4-11](#) for additional details.

Understanding Priority Disconnect

The priority disconnect function differs from the port priority function described on [page 4-8](#) in that it applies only to *the addition of powered devices (PDs) in tight power budget conditions*. Priority disconnect is used by the system software in determining whether an incoming PD will be granted or denied power when there are too few watts remaining in the PoE power budget for an additional device. For example, if there are only 2 watts available in the current PoE power budget and a user plugs a 3.5W powered device into a PoE port, the system software must determine whether the device will be powered on. Based on priority disconnect rules, in some cases one or more existing devices may be powered down in order to accommodate the incoming device. In other cases, the incoming device will be denied power.

Priority disconnect rules involve the port priority status of an incoming device (i.e., low, high, and critical), as well as the port's physical port number (i.e., 1–8). Understanding priority disconnect rules is especially helpful in avoiding power budget deficits and the unintentional shutdown of mission-critical devices when PDs are being added in tight power budget conditions. For detailed information on how priority disconnect uses port priority and port number criteria for determining the power status of incoming PDs, refer to the illustrated examples on pages [4-12](#) through [4-13](#).

Reminder. Priority disconnect applies only when there is inadequate power remaining in the power budget for an incoming device.

For information on setting the priority disconnect status, refer to the section below. For information on setting the port priority status (a separate function from priority disconnect), refer to [“Setting Port Priority Levels” on page 4-8](#).

Setting Priority Disconnect Status

By default, priority disconnect is *enabled* in the switch's system software. For information on changing the priority disconnect status, refer to the information below.

Disabling Priority Disconnect

When priority disconnect is disabled and there is inadequate power in the budget for an additional device, power will be denied to *any* incoming PD, regardless of its port priority status (i.e., low, high, and critical) or physical port number (i.e., 1–8).

To disable priority disconnect, use the **lanpower slot priority-disconnect** command. For example:

```
-> lanpower slot 2/1 priority-disconnect disable
```

Enabling Priority Disconnect

To enable priority disconnect, use the **lanpower slot priority-disconnect** command. For example:

```
-> lanpower slot 2/1 priority-disconnect enable
```

Priority Disconnect is Enabled; Same Priority Level on All PD

Reminder. Priority disconnect examples are applicable only when there is inadequate power remaining to power an incoming device.

When a PD is being connected to a port with the same priority level as all other in the slot, the physical port number is used to determine whether the incoming PD will be granted or denied power. Due to the support of different PoE standards and PoE hardware on each platform the internal port priority is different for each platform. The following should be used to determine PoE priority:

Port Number	1 (Highest) -> 8 (Lowest)
--------------------	---------------------------

PoE Physical Port Priority

Priority Disconnect is Enabled; Incoming PD Port has Highest Priority Level

Reminder. Priority disconnect examples are applicable only when there is inadequate power remaining to power an incoming device.

When a PD is being connected to a port with a *higher priority level* than all other in the slot, the incoming PD will automatically be granted power over the other devices, regardless of its physical port number.

In order to avoid a power budget deficit, another port in the slot is disconnected. In determining which port to power off, the system software first selects the port with the lowest configured priority level. For example, if a *critical priority* device is being added to a slot in which five existing devices are attached to *high priority* and one device is attached to a *low priority* port, the low priority port is automatically disconnected, regardless of its physical port number.

If all existing devices are attached to with the same lower priority level, the system software disconnects the port with both the lowest priority level *and* the highest priority physical port number. For example, if a critical priority device is being added to a slot in which six existing devices are attached to high priority, the high priority port with the lowest physical port priority number is automatically disconnected.

Priority Disconnect is Enabled; Incoming PD Port has Lowest Priority Level

Reminder. Priority disconnect examples are applicable only when there is inadequate power remaining to power an incoming device.

When a PD is being connected to a port with a *lower priority level* than all other in the slot, the incoming PD will be denied power, regardless of its physical port number. Devices connected to other higher-priority will continue operating without interruption.

Priority Disconnect is Disabled

Reminder. Priority disconnect examples are applicable only when there is inadequate power remaining to power an incoming device.

When priority disconnect is disabled, power will be denied to *any* incoming PD, regardless of its port priority status (i.e., low, high, and critical) or physical port number (i.e., 1–8).

Monitoring Power over Ethernet via CLI

To monitor current PoE statistics and settings, use the **show lanpower slot** command. The command output displays a list of all current PoE-capable, along with the following information for each port:

- Maximum power available to the port, in milliwatts
- Actual power used by the port
- Current port status
- Power priority status
- Power on/off status

Aggregate slot and chassis management information is also displayed. This information includes:

- Maximum watts available to the corresponding slot
- Amount of power budget remaining for PoE modules
- Total amount of power remaining for additional switch functions

When entering the **show lanpower** command, you must include a valid slot number in the command line syntax. For example:

```
-> show lanpower 1/1
Port Maximum(mW) Actual Used(mW) Status Priority On/Off Class
-----+-----+-----+-----+-----+-----
  1      60000      12500    Powered On    Low    ON      0
  2      30000       1800    Powered On    Low    ON      1
  3      60000       3500    Powered On    Low    ON      2
  4      30000       9800    Powered On    Low    ON      3
  5      60000      25000    Powered On    Low    ON      4
  6      30000         0    Undefined    Low    ON      -
  7      60000         0    Undefined    Low    ON      -
  8      30000         0    Undefined    Low    ON      -

Slot 3 Max Watts 150
1 Power Supplies Available
```

Note. For detailed information on **show lanpower** command output, refer to the *OmniSwitch CLI Reference Guide*.

A Regulatory Compliance and Safety Information

This appendix provides information on regulatory agency compliance and safety for the OmniSwitch.

Declaration of Conformity: CE Mark

This equipment is in compliance with the essential requirements and other provisions of Directive 2014/30/EU (EMC), 2014/35/EU (LVD), 2011/65/EU (RoHS-Directive), 91/263/EEC (Telecom Terminal Equipment, if applicable), 2014/53/EU (R&TTE, if applicable).

Français: Cet équipement est conforme aux exigences essentielles et aux autres provisions de la Directive 2014/30/EU (EMC), 2014/35/EU (LVD), 2011/65/EU (RoHS-Directive), 91/263/EEC (équipements terminaux de télécommunications, le cas échéant), 2014/53/EU (R&TTE, le cas échéant).

Deutsch: Diese Ausrüstung erfüllt die wesentlichen Anforderungen und sonstigen Bestimmungen der Richtlinien 2014/30/EU (EMV-Richtlinie), 2014/35/EU (LVD), 2011/65/EU (RoHS-Directive), 91/263/EEC (Telekommunikationsendeinrichtungen, falls zutreffend), 2014/53/EU (Funkanlagen und Telekommunikationsendeinrichtungen, falls zutreffend).

Español: Este equipo cumple los requisitos esenciales y otras disposiciones de las directivas 2014/30/EU (EMC), 2014/35/EU (LVD), 2011/65/EU (RoHS-Directive), 91/263/EEC (equipos terminales de telecomunicación, si procede), 2014/53/EU (R&TTE, si procede).

Waste Electrical and Electronic Equipment (WEEE) Statement

The product at end of life is subject to separate collection and treatment in the EU Member States, Norway and Switzerland and therefore marked with the following symbol:

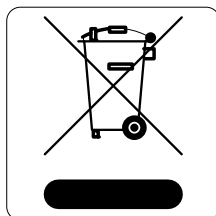

Treatment applied at end of life of the product in these countries shall comply with the applicable national laws implementing directive 2002/96/EC on waste electrical and electronic equipment (WEEE).

China RoHS: Hazardous Substance Table

部件名称 Part Name	有毒和危险品 Toxic and Hazardous Substances or Elements					
	铅 (Pb)	水银 (Hg)	镉 (Cd)	六价铬 (Cr(VI))	多溴化苯 (PBB)	多溴化二苯醚 (PBDE)
电路模块 (Circuit Boards)	X	O	O	O	O	O
电缆及电缆组件 (Cables & Cable Accessories)	X	O	O	O	O	O
金属部件 (Metal Parts)	X	O	O	O	O	O
塑料和聚合物部件 (Plastic and Polymeric parts)	O	O	O	O	O	O
可插拔模块 (Pluggable modules)	X	O	O	O	O	O
电池 (Batteries)	O	O	O	O	O	O

本表格依据 SJ/T 11364 的规定编制

O = 表示该有害物质在该部件所有均质材料中的含量均在 GB/T 26572 规定的限量要求以下 (indicates that the content of the toxic and hazardous substance in all the Homogeneous Materials of the part is below the concentration limit requirement as described in GB/T 26572).

X = 表示该有害物质至少在该部件的某一均质材料中的含量超出 GB/T 26572 规定的限量要求 (indicates that the content of the toxic and hazardous substance in at least one Homogeneous Material of the part exceeds the concentration limit requirement as described in GB/T 26572).

Taiwan RoHS: Hazardous Substance Table

设备名称：交換機和路由器產品						
单位	受限物质及其化学符号					
	铅 (Pb)	汞 (Hg)	镉 (Cd)	六价铬 (Cr+6)	多溴联苯 (PBB)	多溴二苯醚 (PBDE)
电路板 (Circuit Boards)	-	○	○	○	○	○
電纜及電纜配件 (Cables & Cable Accessories)	-	○	○	○	○	○
金屬部件 (Metal Parts)	-	○	○	○	○	○
塑料和聚合物部件 (Plastic and Polymeric Parts)	○	○	○	○	○	○
可插拔模塊 (Pluggable modules)	-	○	○	○	○	○
電池 (Batteries)	○	○	○	○	○	○
注 1: “○” 表示该项受限物质的含量百分比未超过百分比含量基准值。 注 2: “-” 表示该项受限物质为排除项目。						

California Proposition 65 Warning

WARNING: This product can expose you to chemicals including Pb and Pb compounds, which is known to the State of California to cause cancer and birth defects or other reproductive harm. For more information go to www.P65Warnings.ca.gov.

Products are packaged using one or more of the following packaging materials:

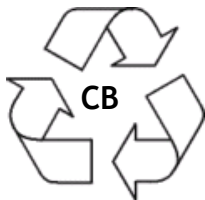

Corrugated Cardboard

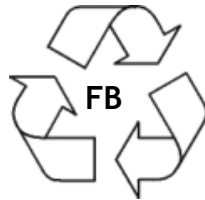

Corrugated Fiberboard



Low-Density Polyethylene

Standards Compliance

The product bears the CE mark. In addition it is in compliance with the following other safety and EMC standards.

Note. All hardware switching modules used in an OmniSwitch switch comply with Class A standards. Modules with copper connectors meet Class A requirements using unshielded (UTP) cables.

Safety Standards

- US UL 60950-1
- IEC 60950-1 Health and Safety
- CAN/CSA-C22.2 No. 60950-1-03
- NOM-019 SCFI, Mexico
- AS/NZ TS-001 and 60950:2000, Australia
- UL-AR, Argentina
- UL-GS Mark, Germany
- CU, EAC, Russia
- EN 60825-1 Laser
- EN 60825-2 Laser
- CDRH Laser
- IEC 60950-1/EN 60950 with all country
- deviations
- IEC 60950-1:2005, Second Edition
- CCC, China
- ANATEL, Brazil (Contact for availability)
- BSMI, Taiwan (Contact for availability)
- KCC, Korea (Contact for availability)

EMI/EMC Standards

- FCC Part 15:2012, Subpart B, Class A
- ICES–003:2012 Issue 5, Class A
- ANSI C63.4-2009
- FCC CRF Title 47 Subpart B (Class A)
- VCCI (Class A)
- AS/NZS 3548 (Class A)
- CE marking for European countries (Class A)
- EN 55032 (EMI & EMC)
- EN 61000-3-2
- EN 61000-3-3
- EN 55024 (Immunity)
 - EN 61000-4-2
 - EN 61000-4-3
 - EN 61000-4-4
 - EN 61000-4-5
 - EN 61000-4-6
 - EN 61000-4-8
 - EN 61000-4-11
- IEEE 802.3: Hi-Pot Test
(2250 V DC on all Ethernet ports)

Environmental Standards

- IEC 60068-2-1
- IEC 60068-2-2
- IEC 60068-2-30
- IEC 60068-2-13
- IEC 60068-2-40
- IEC 60068-2-41
- IEC 6068-2-6
- IEC 60068-2-64
- IEC 60068-2-27
- GR-63-CORE
- MIL-STD-810F Method 516.5 IV
- MIL-STD-810F Method 516.5 C

Industrial Compliance Requirements (Not applicable to OS6465T models)

Safety

- ISA 12.12.01 (UL 1604), CSA22.2/213, UL 508, EN50021

Operational Temperature

- IEC 60870-2-2 (operational temperature)
- IEC 60068-2-1 (temperature type test - cold)
- IEC 60068-2-2 (temperature type test - hot)

Storage Temperature

- IEC 60721-3-1: Class 1K5 (storage temperature)

Humidity

- IEC 60068-2-30: 5% to 95% non-condensing humidity

Mechanical Shock

- IEC 60255-21-2 (mechanical shock)

Vibration

- IEC 60255-21-1 (vibration)

Drop Test

- IEC 60870-2-2 Free Fall

Altitude Test

- IEC 60870-2-2, GR-63-CORE, 4.1.3, 4.5

IPX

- IPXX, IEC60529

EMI/EMC

- IEC 61000-6-2 (Immunity), EN 61000-6-4 (Emission), EN 55032, EN 61000-3-3, EN 61000-3-2, EN 55024, IEC 61850-3, EN 61000-4-2 to EN 61000-4-6, EN 61000-4-8, EN 61131-2 IEEE 1613, Section 5.2, 5.3, 6.3.1, 6.3.2, 7, 8

DNV

- DNV 2.4

Railway

- EN 50121-4, IEC 62236-4, EN 61000-6-4

NEMA

- NEMA TS-2

FCC Class A, Part 15

This equipment has been tested and found to comply with the limits for Class A digital device pursuant to Part 15 of the FCC Rules. These limits are designed to provide reasonable protection against harmful interference when the equipment is operated in a commercial environment. This equipment generates, uses, and can radiate radio frequency energy and, if not installed and used in accordance with the instructions in this guide, may cause interference to radio communications. Operation of this equipment in a residential area is likely to cause interference, in which case the user will be required to correct the interference at his own expense.

The user is cautioned that changes and modifications made to the equipment without approval of the manufacturer could void the user's authority to operate this equipment. It is suggested that the user use only shielded and grounded cables to ensure compliance with FCC Rules.

If this equipment does cause interference to radio or television reception, the user is encouraged to try to correct the interference by one or more of the following measures:

- Reorient the receiving antenna.
- Relocate the equipment with respect to the receiver.
- Move the equipment away from the receiver.
- Plug the equipment into a different outlet so that equipment and receiver are on different branch circuits.

If necessary, the user should consult the dealer or an experienced radio/television technician for additional suggestions.

Canada Class A Statement

This equipment does not exceed Class A limits per radio noise emissions for digital apparatus, set out in the Radio Interference Regulation of the Canadian Department of Communications.

Avis de conformité aux normes du ministère des Communications du Canada

Cet équipement ne dépasse pas les limites de Classe A d'émission de bruits radioélectriques pour les appareils numériques, telles que prescrites par le Règlement sur le brouillage radioélectrique établi par le ministère des Communications du Canada.

JATE

This equipment meets the requirements of the Japan Approvals Institute of Telecommunications Equipment (JATE).

CISPR22 Class A warning

This is a Class A product. In a domestic environment, this product may cause radio interference. Under such circumstances, the user may be requested to take appropriate countermeasures.

Korea Emissions Statement

A 급 기기 (업무용 방송통신 기자재)
이 기기는 업무용 (A 급) 전자파적합기기로서 판
매자 또는 사용자는 이 점을 주의하시기 바라
며, 가정외의 지역에서 사용하는 것을 목적으
로 합니다.

Class A Equipment (Business equipment)
This equipment is registered for Electromagnetic
Conformity Registration as business equipment
(A), not home equipment. Sellers or users are
required to take caution in this regard.

VCCI

This is a Class A product based on the standard of the Voluntary Control Council for Interference by Information Technology Equipment (VCCI). If this equipment is used in a domestic environment, radio disturbance may arise. When such trouble occurs, the user may be required to take corrective actions.

この装置は、情報処理装置等電波障害自主規制協議会（VCCI）の基準に基づくクラスA情報技術装置です。この装置を家庭環境で使用すると電波妨害を引き起こすことがあります。この場合には使用者が適切な対策を講ずるよう要求されることがあります。

Class A Warning for Taiwan and Other Chinese Markets

This is a Class A Information Product. When used in a residential environment, it may cause radio frequency interference. Under such circumstances, the user may be requested to take appropriate countermeasure.

警告使用者：
這是甲類的資訊產品，在居住的環境中使用時，
可能會造成射頻干擾，在這種情況下，使用者會
被要求採取某些適當的對策。

Class 1M Laser Warning

CLASS 1M LASER RADIATION WHEN OPEN. DO NOT VIEW DIRECTLY WITH OPTICAL INSTRUMENTS.

Network Cable Installation Warning

Never install exposed network cables outdoors. Install network cables per manufacturer requirements.

Translated Safety Warnings

Blank Panels Warning

Because they regulate airflow and help protect internal chassis components, blank cover plates should remain installed at empty module slots and power supply bays at all times.

Français: Les caches blancs remplissent trois fonctions importantes: ils évitent tout risque de choc électrique à l'intérieur du châssis, ils font barrage aux interférences électromagnétiques susceptibles d'altérer le fonctionnement des autres équipements et ils dirigent le flux d'air de refroidissement dans le châssis. Il est vivement recommandé de vérifier que tous les caches, modules d'alimentation et plaques de protection sont en place avant d'utiliser le système.

Deutsch: Die leeren Modulblenden schützen interne Komponenten und leiten den Luftstrom. Deshalb müssen in allen unbelegten Slots die Modulblenden immer installiert bleiben.

Español: Las tapaderas blancas regulan la circulación de aire y ayudan a proteger componentes internos del chasis y siempre deben estar instaladas en las ranuras vacías del chasis y fuentes de alimentación.

Electrical Storm Warning

To avoid a shock hazard, do not connect or disconnect any cables or perform installation, maintenance, or reconfiguration of this product during an electrical storm.

Français: Ne pas travailler sur le système ni brancher ou débrancher les câbles pendant un orage.

Deutsch: Um elektrische Schläge zu vermeiden dürfen während eines Gewitters an diesem Gerät keine Kabel angeschlossen oder gelöst werden, sowie keinerlei Installationen, Wartungen oder Konfigurationen vorgenommen werden.

Español: Para evitar peligro de descargas, no conecte o desconecte ningún cable, ni realice ninguna instalación, mantenimiento o reconfiguración de este producto durante una tormenta eléctrica.

Installation Warning

Only personnel knowledgeable in basic electrical and mechanical procedures should install or maintain this equipment.

Français: Toute installation ou remplacement de l'appareil doit être réalisée par du personnel qualifié et compétent.

Deutsch: Dieses Gerät soll nur von Personal installiert oder gewartet werden, welches in elektrischen und mechanischen Grundlagen ausgebildet ist.

Español: Estos equipos deben ser instalados y atendidos exclusivamente por personal adecuadamente formado y capacitado en técnicas eléctricas y mecánicas.

Invisible Laser Radiation Warning

Lasers emit invisible radiation from the aperture opening when no fiber-optic cable is connected. When removing cables do not stare into the open apertures. In addition, install protective aperture covers to fiber ports with no cable connected.

Français: Des radiations invisibles à l'œil nu pouvant traverser l'ouverture du port lorsque aucun câble en fibre optique n'y est connecté, il est recommandé de ne pas regarder fixement l'intérieur de ces ouvertures. Installez les caches connecteurs prévus à cet effet.

Deutsch: Die Laser strahlen an der Blendenöffnung unsichtbares Licht ab, wenn keine Glasfaserkabel angeschlossen sind. Blicken Sie nicht in die Öffnungen und installieren Sie unverzüglich die Abdeckungen über den Glasfaseranschlüssen.

Español: Debido a que la apertura del puerto puede emitir radiación invisible cuando no hay un cable de fibra conectado, procurar no mirar directamente a las aperturas para no exponerse a la radiación.

Operating Voltage Warning

To reduce the risk of electrical shock, keep your hands and fingers out of power supply bays and do not touch the backplane while the switch is operating.

Français: Pour réduire tout risque électrique, gardez vos mains et doigts hors des alimentations et ne touchez pas au fond de panier pendant que le commutateur fonctionne.

Deutsch: Um die Gefahr des elektrischen Schlages zu verringern, greifen sie bitte nicht in die Spannungsversorgung und berühren sie nicht die Rückwandplatine während das Gerät arbeitet.

Español: Para reducir el riesgo de descargas eléctricas, no meta sus manos y dedos dentro del chasis de la fuente de alimentación y no toque componentes internos mientras que el interruptor está conectado.

Power Disconnection Warning

Your switch is equipped with multiple power supplies. To reduce the risk of electrical shock, be sure to disconnect all power connections before servicing or moving the unit.

Français: Il se peut que cette unité soit équipée de plusieurs raccordements d'alimentation. Pour supprimer tout courant électrique de l'unité, tous les cordons d'alimentation doivent être débranchés.

Deutsch: Ihr Gerät ist mit mehreren Netzteilen ausgerüstet. Um die Gefahr des elektrischen Schlages zu verringern, stellen sie sicher, daß alle Netzverbindungen getrennt sind bevor das Gerät gewartet oder bewegt wird.

Español: Antes de empezar a trabajar con un sistema, asegurese que el interruptor está cerrado y el cable eléctrico desconectado.

Proper Earthing Requirement Warning

To avoid shock hazard:

- The power cord must be connected to a properly wired and earth receptacle.
- Any equipment to which this product will attached must also be connected to properly wired receptacles.

Français:

Pour éviter tout risque de choc électrique:

- Ne jamais rendre inopérant le conducteur de masse ni utiliser l'équipement sans un conducteur de masse adéquatement installé.
- En cas de doute sur la mise à la masse appropriée disponible, s'adresser à l'organisme responsable de la sécurité électrique ou à un électricien.

Deutsch:

Aus Sicherheitsgründen:

- darf das Netzkabel nur an eine Schutzkontaktsteckdose angeschlossen werden.
- dürfen für den Anschluß anderer Geräte, welche mit diesem Gerät verbunden sind, auch nur Schutzkontaktsteckdosen verwendet werden.

Español:

Para evitar peligro de descargas:

- Para evitar peligro de descargas asegurese de que el cable de alimentación está conectado a una toma de alimentación adecuadamente cableada y con toma de tierra.
- Cualquier otro equipo a cual se conecte este producto también debe estar conectado a tomas de alimentación adecuadamente cableadas.

DC Power Supply Connection Warning

For EMC/EMI, each DC/DC power supply requires that the ground wire is connected from each DC/DC power supply to Common Earth Ground.

Français: Pour EMC/EMI, pour chaque alimentation DC/DC, il est impératif que le fil de terre soit branché à la prise de terre commune.

Deutsch: Zur Erfüllung der EMV-/EMI-Anforderungen muss das Erdungskabel jedes DC/DC-Netzteils an eine gemeinsame Erde angeschlossen werden.

Español: Para EMC/EMI, cada fuente de alimentación de CC/CC requiere que el cable de tierra esté conectado desde cada fuente de alimentación de CC/CC a la conexión a tierra común.

Read Important Safety Information Warning

The *Getting Started Guide* that accompanied this equipment contains important safety information about which you should be aware when working with hardware components in this system. You should read this guide before installing, using, or servicing this equipment.

Français: Avant de brancher le système sur la source d'alimentation, consultez les directives d'installation disponibles dans le "Getting Started Guide".

Deutsch: Der Getting Started Guide, welcher dieser Anlage beiliegt, enthält wichtige Sicherheitsinformationen, über die sie sich beim Arbeiten mit den Hardwareeinheiten bewußt sein sollten. Sie sollten diese Hinweise lesen, bevor sie installieren, reparieren oder die Anlage verwenden.

Español: La 'Getting Started Guide' que acompañó este equipo contiene información importante de seguridad sobre la cual usted debe estar enterado al trabajar con los componentes de dotación física en este sistema. Usted debe leer esta guía antes de instalar, usar o mantener este equipo.

Restricted Access Location Warning

This equipment should be installed in a location that restricts access. A restricted access location is one where access is secure and limited to service personnel who have a special key, or other means of security.

Français: Le matériel doit être installé dans un local avec accès limité ou seules les personnes habilitées peuvent entrer.

Deutsch: Die Anlage sollte an einem Standort mit beschränktem Zutritt installiert sein. Ein Standort mit beschränktem Zutritt stellt sicher, daß dort nur Servicepersonal mit Hilfe eines Schlüssels oder eines anderen Sicherheitssystems Zugang hat.

Español: Este equipo se debe instalar en un sitio con acceso restringido. Un sitio con el acceso restringido es uno seguro y con acceso limitado al personal de servicio que tiene una clave especial u otros medios de seguridad.

Wrist Strap Warning

Because electrostatic discharge (ESD) can damage switch components, you must follow proper procedures to eliminate ESD from your person and the surrounding area before handling switch components.

Français: Parce que les décharges électrostatiques (ESD) peuvent endommager les composants de commutation, vous devez suivre les procédures appropriées pour éliminer ESD de votre personne et la région environnante avant de manipuler les composants de commutation.

Deutsch: Da elektrostatische Entladung (ESD) Komponenten beschädigen können, müssen geeignete Verfahren getroffen werden, diese elektrostatische Entladung bedingt durch Ihre Person oder der Umgebung zu beseitigen.

Español: Debido a las descargas electrostáticas (ESD) puede dañar los componentes del interruptor, debe seguir los procedimientos adecuados para eliminar la ESD de su persona y sus alrededores antes de manipular los componentes del interruptor.

Instrucciones de seguridad en español

Advertencia sobre el levantamiento del chasis

Se requieren dos personas para levantar el chasis. Debido a su peso, la elevación del chasis sin ayuda puede causar daños corporales. También es seguro doblar sus rodillas y guardar su espalda derecho al ayudar a levantar el chasis.

Advertencia de las tapaderas en blanco

Porque regulan la circulación de aire y ayudan a proteger componentes internos del chasis, las tapaderas en blanco deben seguir instaladas en las ranuras vacías del módulo y la fuente de alimentación siempre.

Advertencia en caso de tormenta eléctrica

Para evitar peligro de descargas, no conecte o desconecte ningún cable, ni realice ninguna instalación, mantenimiento o reconfiguración de este producto durante una tormenta eléctrica.

Advertencia de instalación

Solamente el personal bien informado en procedimientos eléctricos y mecánicos básicos debe instalar o mantener este equipo.

Advertencia de radiación láser invisible

Los lasers emiten radiación invisible de la apertura abierta cuando no se conecta ningún cable de fibra óptica. Al quitar los cables no mire fijamente en las aberturas abiertas. Además, instale las cubiertas protectoras de la apertura a las salidas de la fibra sin el cable conectado.

Advertencia de la batería de litio

Hay un peligro de la explosión si la batería del litio en su chasis se substituye incorrectamente. Substituya la batería solamente por el mismo o el equivalente de tipo de batería recomendado por el fabricante. Deseche las baterías usadas según las instrucciones del fabricante. Las instrucciones del fabricante son como sigue: Devuelva el módulo con la batería del litio a Alcatel-Lucent. La batería del litio será substituida en la fábrica de Alcatel-Lucent.

Advertencia sobre la tensión de operación

Para reducir el riesgo del choque eléctrico, mantenga sus manos y dedos fuera de la fuente de alimentación y no toque la placa madre mientras que el interruptor está funcionando.

Advertencia sobre la desconexión de la fuente

Su interruptor esta equipado por fuentes de alimentación múltiples. Para reducir el riesgo de choque eléctrico, asegúrese desconectar todas las conexiones de alimentación antes de mantener o de mover la unidad.

Advertencia sobre una apropiada conexión a tierra

Para evitar peligro de descargas:

- El cable de alimentación debe estar conectado a una toma de alimentación adecuadamente cableada y con toma de tierra.

Cualquier equipo al cual se conecte este producto debe estar también conectado a tomas de alimentación adecuadamente cableadas.

Leer “información importante de seguridad”

La *Guía de “Comenzando a Usar”* que acompaña este equipo contiene información importante de seguridad sobre la cual usted debe saber al trabajar con los componentes de dotación física en este sistema. Usted debe leer esta guía antes de instalar, de usar, o de mantener este equipo.

Advertencia de acceso restringido

Este equipo se debe instalar en una ubicación que restrinja el acceso. Una ubicación con acceso restringido es una donde está seguro y limitado el acceso al personal de servicio que tiene un clave especial, u otros medios de la seguridad.

Advertencia de pulsera antiestática

Debido a que la descarga electrostática (ESD) puede dañar componentes del interruptor, usted debe conectarse a tierra correctamente antes de continuar con la instalación del equipo. Para este propósito, Alcatel-Lucent proporciona una pulsera antiestática y un terminal que pone a tierra situados cerca de la parte superior derecha del chasis. Para que la pulsera antiestática sea eficaz en la eliminación de ESD, las fuentes de alimentación se deben instalar en el chasis y enchufar en las salidas de CA con descarga a tierra.

Clase de seguridad

Cumple con 21CFR 1040.10 y 1040.11 ó sus equivalentes.

Advertencia de fuentes de poder

Las unidades OmniSwitch pueden estar equipadas con tres cordones para fuente de poder. Para reducir el riesgo de un choque eléctrico, desconecte todos los cordones de fuente de poder antes de dar servicio a la unidad.